

HD T/A FRONT & REAR UNLOAD FORAGE BOX

OPERATOR'S MANUAL & PARTS BOOK



WARNING

READ AND UNDERSTAND THIS MANUAL BEFORE OPERATING THIS EQUIPMENT. UNSAFE OPERATION OR MAINTENANCE OF THIS EQUIPMENT CAN RESULT IN SERIOUS INJURY OR DEATH.

HSMFG0416

Manufactured By
H&S MANUFACTURING CO., INC.
P.O. BOX 768 • (715) 387-3414 FAX (715) 384-5463
MARSHFIELD, WISCONSIN 54449

CONTENTS

Warranty & Warranty Registration Card.....	1-2
Dealer Pre-Delivery & Delivery Checklist.....	3
Be Alert Symbol.....	5
Explanation of Safety Signs.....	6
Danger - Warning Signs.....	7-8
Warning - Owner Must Read and Understand.....	9
Warning - Emergency Stop.....	10
Bolt Torque Chart.....	11
Set-Up & Assembly.....	12
Transporting.....	13
Preparing for Operation.....	14-15
Operation.....	16-18
Adjustments.....	19-22
Service.....	23-24
Optional Features & Accessories.....	25
Lubrication Guide.....	26-27
Decal Location & Identification.....	28-29
Instructions For Ordering Parts.....	30
Parts.....	31-53
Service Notes.....	54

WARRANTY

H&S WARRANTY

H&S Manufacturing Co., Inc. ("H&S") warrants this product to be free from defect in material and workmanship. Except as noted below, this warranty term is twelve (12) months from the date of delivery of the product to the original purchaser by an authorized H&S dealer. Under this warranty, H&S will repair or replace, at its option, any covered part which is found to be defective in material or workmanship during the applicable warranty term. In no case will the covered repair cost of a part or parts exceed the replacement cost of that part. Warranty service must be performed by H&S or a dealer authorized by H&S to sell and/or service the product involved, which will use only new or remanufactured parts or components furnished by H&S. This warranty includes approved parts and labor to fix the product but does not include, and the purchaser is responsible for, any service call and/or transportation of the product to and from the dealer's place of business, for any premium charged for overtime labor requested by the purchaser, and for any service work not directly related to any defect covered under this warranty. This warranty includes only those components of the product manufactured by H&S. Warranty for any component not manufactured by H&S including, but not limited to, engines, batteries, tires, rims, hydraulic motors, pumps, etc. are covered by the warranty, if any, provided separately by their respective manufacturers.

This warranty in all its parts, is extended solely to the original purchaser of the product, is terminated upon any subsequent transfer or sale from or by the original purchaser and extends no third party benefits or rights whatsoever.

The warranty term for any product used in any commercial, custom, for hire or rental application, is limited to six (6) months from the date of delivery of the product to the original purchaser or the first day of service, whichever comes first, by an authorized H&S dealer.

Floor and side panels utilized in H&S Manure Spreaders are warranted, to the original purchaser, to not wear through or delaminate for 10 years when used to spread normal agricultural manure. The frame, sides, end, floor and roof of forage boxes are warranted to not wear or rust through for 10 years when the forage box is used to transport freshly chopped forage. These specific warranties include only replacement of any defective panel part without any allowance for labor beyond the terms of the standard H&S 12 month warranty.

For commercial, custom for hire, or rental application, warranty is limited to 6 months from the date of delivery to the original purchaser, or the first day in service, whichever is earlier.

This warranty does not include: (1) Any product that has been altered or modified in ways not approved by H&S; (2) Depreciation or damage caused by normal wear, misuse, improper or insufficient maintenance, improper operation, accident or failure to follow the product Operator's Manual recommendations and product decal recommendations; (3) Normal maintenance parts and service; (4) Repairs made with parts other than those available from H&S or performed by anyone other than H&S or a dealer authorized by H&S to sell and/or service the product involved.

To secure warranty service the purchaser must report the product defect to a dealer authorized by H&S to sell and/or service the product involved within the applicable warranty term together with evidence of the warranty start date and make the product available to that dealer within a reasonable period of time.

HERE ARE NO WARRANTIES WHICH EXTEND BEYOND THE DESCRIPTION ON THE FACE OF THIS WARRANTY. H&S and the companies affiliated with it makes no warranties, representations, or promises, express or implied, as to the performance or freedom from defect of its products other than those set forth above and **NO IMPLIED WARRANTY OF MERCHANTABILITY, FITNESS OR FITNESS FOR A PARTICULAR PURPOSE IS MADE. IN NO EVENT WILL THE DEALER, H&S OR ANY COMPANY AFFILIATED WITH H&S BE LIABLE FOR INCIDENTAL OR CONSEQUENTIAL DAMAGES.** The **ONLY REMEDY** the purchaser has in connection with the breach of performance of any warranty on H&S products are those set forth above.

The selling dealer has no authority to make any representation or promise on behalf of H&S, or to modify the terms or limitations of this warranty in any way.

12/13

**FILL OUT
AND MAIL
IMMEDIATELY
TO MAKE
WARRANTY
EFFECTIVE**



WARRANTY REGISTRATION

Date of Purchase _____

Purchaser _____ Address _____

City _____ State _____ Zip _____

Product _____ Model# _____ Serial# _____

Dealer _____ Address _____

City _____ State _____ Zip _____

Signature of Original Buyer

MANUFACTURER'S STATEMENT

Your New H&S Product has been manufactured of the finest quality materials and components. The performance you get from your machine is largely dependent upon how well you read and understand this manual and apply this knowledge. There is a right and a wrong way to do everything. Please do not assume that you know how to operate and maintain your Machine before reading this manual carefully. Keep this manual available for ready reference.

IMPORTANT!

Tear on the dotted line, provide the information requested on the card. The H&S Warranty is valid **“only”** after this card is received and recorded at H&S Manufacturing Co., Inc. Mail at once. No postage is required in the U.S.A.



NO POSTAGE
NECESSARY
IF MAILED
IN THE
UNITED STATES

BUSINESS REPLY MAIL

FIRST CLASS MAIL Permit No.195 Marshfield, WI 54449

POSTAGE WILL BE PAID BY ADDRESSEE

H&S Manufacturing Co., Inc.
PO Box 768
Marshfield, WI 54449-9963



DEALER PRE-DELIVERY CHECK LIST

After the Forage Box has been completely set-up, check to be certain it is in correct running order before delivering to the customer. The following is a list of points to inspect. Check off each item as you have made the proper adjustments and found the item operating satisfactorily.

- Forage Box was not damaged in shipment. Check for dents and loose or missing parts. Report damage immediately to H&S Manufacturing Co., Inc.
- Forage Box has been correctly assembled according to the instructions in this manual.
- All shields and guards are in place and fastened.
- PTO shields turn freely.
- All grease fittings have been lubricated and gear boxes filled to proper level – See lubrication guide in this manual.
- All mechanisms are operating trouble free.
- All roller chains are at proper tension.
- Apron chains are adjusted properly.
- All bolts and fasteners are tight.
- 2 extra shear bolts are provided.
- All decals are in place and legible.

	Model Number
(Dealer's Name)	Serial Number
(Signature of Pre-Delivery Inspector)	(Inspection Date)

DEALER DELIVERY CHECK LIST

This check list that follows is an important reminder of valuable information that should be passed on to the customer at the time this Self-Unloading Forage Box is delivered. Check off each item as you explain it to the customer. This pre-delivery check list, when properly filled out and signed assures the customer that the pre-delivery service was satisfactorily performed.

- Explain to the customer that the pre-delivery inspection was made.
- Explain to the customer all the safety precautions they must exercise when operating this unit.
- Explain recommended loads for different types of materials.
- Explain to customer that regular lubrication is required for proper operation and long life of machine. Show customer the lubrication section of Owner's Manual.
- Give the customer Owner's Manual and make sure he reads and understands all operating and service instructions.
- Record Serial Number in this Manual.
- Have customer sign a completed "Warranty Registration," and mail it promptly.

Dealer's Name _____ By _____

Signature of Original Buyer _____ Date _____

Note: Warranty is not valid until warranty card is completed and returned to H&S Mfg. Co., Inc.

INTENTIONALLY LEFT BLANK

SAFETY INFORMATION



**BE
ALERT!**

**YOUR SAFETY
IS INVOLVED.**

THIS SYMBOL IS USED THROUGHOUT THIS BOOK WHENEVER YOUR PERSONAL SAFETY IS INVOLVED. TAKE TIME TO BE CAREFUL. REMEMBER: THE CAREFUL OPERATOR IS THE BEST OPERATOR. MOST ACCIDENTS ARE CAUSED BY HUMAN ERROR. CERTAIN PRECAUTIONS MUST BE OBSERVED TO PREVENT THE POSSIBILITY OF INJURY OR DAMAGE.

H&S MANUFACTURING CO. INC.

SAFETY INFORMATION

Keep signs in good condition. Immediately replace any missing or damaged signs.

RECOGNIZE SAFETY INFORMATION

This is the safety-alert symbol. When you see this symbol on your machine or in this manual, be alert to the potential for personal injury.

Follow recommended precautions and safe operating practices.



UNDERSTAND SIGNAL WORDS

A signal word - DANGER, WARNING, or CAUTION is used with the safety alert symbol. DANGER identifies the most serious hazards.

Safety signs with signal word DANGER or WARNING are typically near specific hazards.

General precautions are listed on CAUTION safety signs.



WARNING



CAUTION



CAUTION

FOLLOW SAFETY INSTRUCTIONS

Carefully read all safety messages in this manual, and all safety signs on your machine. Follow all recommended precautions and safe operating procedures.

OBSERVE MAXIMUM TRANSPORT SPEED

The maximum transport speed for this implement is 32 km/h (20 m.p.h.).

Some tractors are capable of operating at speeds that exceed the maximum transport speed of this implement. Regardless of the maximum speed capability of the tractor being used to tow this implement, do not exceed the implement's maximum transport speed.

Exceeding the implements maximum transport speed can result in:

- * Loss of control of the tractor/implement combination
- * Reduced or no ability to stop during braking
- * Implement tire failure
- * Damage to the implement structure or its component

Use additional caution and reduce speed when towing under adverse surface conditions, when turning, and when on inclines.

Do not attempt transport if the fully loaded implement weighs more than 1.5 times the weight of the tractor.



SAFETY INFORMATION

! DANGER



STAY CLEAR OF BEATER AND/OR CROSS CONVEYOR IF POWER SOURCE OR PTO IS RUNNING

FAILURE TO HEED THIS WARNING MAY RESULT IN PERSONAL INJURY OR DEATH

KEEP CLOTHING, YOURSELF AND OTHERS WELL CLEAR.

1494H

! WARNING!



KEEP CHILDREN AWAY AT ALL TIMES!

2495

! DANGER



ROTATING DRIVELINE CONTACT CAN CAUSE DEATH
KEEP AWAY!

DO NOT OPERATE WITHOUT—

- ALL DRIVELINE GUARDS, TRACTOR AND EQUIPMENT SHIELDS IN PLACE
- DRIVELINES SECURELY ATTACHED AT BOTH ENDS
- DRIVELINE GUARDS THAT TURN FREELY ON DRIVELINE

! DANGER



ROTATING DRIVELINE CONTACT CAN CAUSE DEATH

5896B

! DANGER



MAINTAIN SAFE CLEARANCE FROM ELECTRIC POWER LINES AND AVOID CONTACT WITH ANY ELECTRICALLY CHARGED CONDUCTOR.

CONTACT WITH ELECTRIC POWER SOURCES CAN RESULT IN ELECTRICAL SHOCK OR ELECTROCUTION.

FAILURE TO HEED THIS WARNING MAY RESULT IN SERIOUS INJURY OR DEATH.

1494P

! WARNING

WHEN OPERATING FORGE BOX AS A REAR UNLOAD, OPERATOR SHOULD REMAIN IN TRACTOR SEAT AND KEEP ALL OTHERS WELL CLEAR.

EMERGENCY STOP DOES NOT STOP FORGE BOX WHEN BEING OPERATED AS A REAR UNLOAD.

1494Q

! DANGER



KEEP OUT

DISENGAGE ALL POWER AND SHUT OFF TRACTOR ENGINE BEFORE ATTEMPTING TO ENTER OR CLEAN FORGE BOX

FAILURE TO HEED THIS WARNING MAY RESULT IN PERSONAL INJURY OR DEATH

1494I

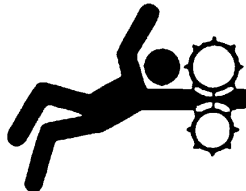

! DANGER

NEVER ENTER FORGE BOX UNLESS THE FOLLOWING SAFETY PRECAUTIONS ARE FOLLOWED.

1494F



! WARNING

EMERGENCY STOP CABLE FUNCTIONS ONLY WHEN FORGE BOX IS BEING OPERATED AS A FRONT UNLOAD

1494O



! WARNING

DO NOT GO NEAR LEAKS

- High pressure oil easily punctures skin causing serious injury, gangrene or death.
- If injured, seek emergency medical help. Immediate surgery is required to remove oil.
- Do not use finger or skin to check for leaks.
- Lower load or relieve hydraulic pressure before loosening fittings.

11599

SAFETY INFORMATION

 <h2 style="margin: 0;">WARNING</h2>	<p>TO PREVENT SERIOUS INJURY OR DEATH NEVER OPERATE THIS UNIT UNLESS EMERGENCY STOP FUNCTIONS PROPERLY.</p> <p style="text-align: right; font-size: small;">5896C</p>
--	--

 <h3 style="margin: 0;">WARNING</h3>

<p>DO NOT REMOVE SHIELDS</p> <p>MOVING PARTS INSIDE</p> <p style="font-size: x-small;">1494K</p>

 <h3 style="margin: 0;">WARNING</h3>
<h4 style="margin: 0;">HELP AVOID INJURY</h4>
<ul style="list-style-type: none"> • READ & UNDERSTAND THE OPERATORS MANUAL PROVIDED WITH THIS MACHINE. IF MISPLACED CALL H & S MANUFACTURING AT 715-387-3414 WITH MODEL AND NUMBER. • UNDERSTAND ALL SAFETY WARNINGS AND FUNCTION OF CONTROLS. • KEEP SAFETY DEVICES IN PLACE AND WORKING. • KEEP YOURSELF AND OTHERS WELL CLEAR OF MOVING PARTS. • DISCONNECT ALL POWER BEFORE SERVICING OR CLEANING THIS MACHINE. • O NOT EXCEED 20 MPH <p style="text-align: right; font-size: x-small;">72203A</p>

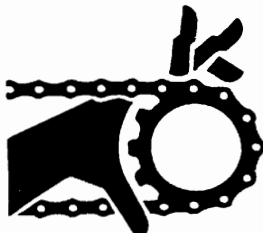
 <h3 style="margin: 0;">WARNING</h3>

<p>DO NOT CLEAN OR WORK ON THIS MACHINE WITHOUT FIRST DISENGAGING POWER AND SHUTTING OFF TRACTOR ENGINE.</p> <p style="text-align: right; font-size: x-small;">1494J</p>

 <p style="font-size: x-small;">1494B</p>	<p>WARNING</p> <p>DO NOT REMOVE SHIELDS</p> <p>MOVING PARTS INSIDE</p>
--	---

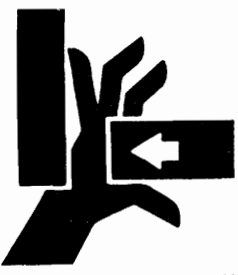
 <p style="font-size: x-small;">1494E</p>	<p>WARNING</p> <p>DO NOT INSTALL BOLSTER PLATES ONTO BOX STRINGER WITHOUT BLOCKING BOX IF BOX IS RAISED UP</p>
---	--

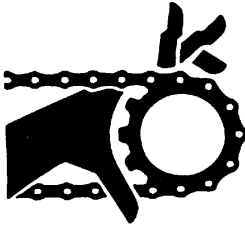
 <p style="font-size: x-small;">1494C</p>	<p>WARNING</p> <p>STAY CLEAR</p> <p>MOVING PARTS</p> <p>UNDER THIS AREA</p>
--	---

 <p style="font-size: x-small;">1494A</p>	<p>WARNING</p> <p>DO NOT OPERATE THIS EQUIPMENT IF THIS DECAL IS EXPOSED. REPLACE SAFETY SHIELDS.</p>
---	---

TRACTOR:

This Operators Manual uses the term "Tractor" when identifying the power source.



TO PREVENT SERIOUS INJURY OR DEATH

BEFORE YOU ATTEMPT TO OPERATE THIS EQUIPMENT, READ AND STUDY THE FOLLOWING INFORMATION. IN ADDITION, MAKE SURE THAT EVERY INDIVIDUAL WHO OPERATES OR WORKS WITH THIS EQUIPMENT, WHETHER FAMILY MEMBER OR EMPLOYEE, IS FAMILIAR WITH THESE SAFETY PRECAUTIONS. KNOW HOW TO STOP UNLOADING MECHANISM BEFORE STARTING IT.

EMERGENCY STOP DOES NOT STOP FORAGE BOX WHEN BEING OPERATED AS A REAR UNLOAD.

If the machine becomes clogged, disengage the PTO or tractor hydraulics. Stop the tractor engine and allow all mechanisms to stop before cleaning or working on the machine.

DO NOT attempt to perform maintenance or repair with tractor running and PTO or tractor hydraulics hooked up.

DO NOT step up on machine at any time.

NEVER manually feed material into the beaters.

DO NOT allow minors to operate or be near the machine.

DO NOT ALLOW PERSONNEL OTHER THAN THE QUALIFIED OPERATOR NEAR THE MACHINE.

BEFORE starting tractor, be sure PTO shields turn freely and PTO is securely locked to tractor.

DO NOT clean, adjust, or lubricate the machine when any part is in operation.

CHECK frequently to be assured that the emergency stop mechanism is in proper operating condition. **KEEP** hands, feet, and clothing away from beaters when they are revolving .

LOOSE or floppy clothing should not be worn by the operator.

BE SURE the machine is clear of people, tools, and other objects before engaging PTO or tractor hydraulics.

STAY CLEAR of hydraulic lines and fittings. They may be under extreme pressure or heat.

DO NOT step over power take off shaft. Stay clear of PTO at all times.

NEVER start forage box until all guards and safety shields are secured in place.

NEVER put hand in cross conveyor outlet openings while tractor is running.

CAUTION – Beware of low electrical wires.

NEVER hook up 1000 RPM tractor to the forage box.

STAY CLEAR of rear of forage box at all times.

H&S Mfg. Co. always takes the operator and his safety into consideration and guards exposed moving parts for his protection. However, some areas cannot be guarded or shielded in order to assure proper operation. In addition, the operators manual and decals on the machine itself warn you of further danger and should be read and observed closely.

Study The Above Safety Rules
ATTENTION - BE ALERT - YOUR SAFETY IS INVOLVED

SAFETY INFORMATION



WARNING

**TO PREVENT SERIOUS INJURY OF DEATH NEVER OPERATE THIS UNIT
UNLESS EMERGENCY STOP FUNCTIONS PROPERLY**

EMERGENCY STOP

1. In case of an emergency, pushing either the stop panel rearward (A), or pulling the trip cables (B) will stop cross conveyor, beaters, and main apron.
2. Activating emergency stop only stops box functions. The PTO shaft will continue to rotate.
3. Keep excessive slack out of trip cables.
4. Trip emergency stop occasionally, and when starting the unit after periods of storage to insure proper function.
5. To reset, move lever (C) clock wise to engage position.

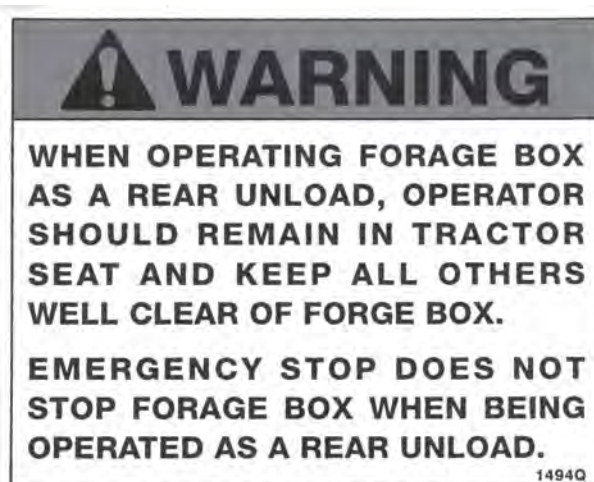
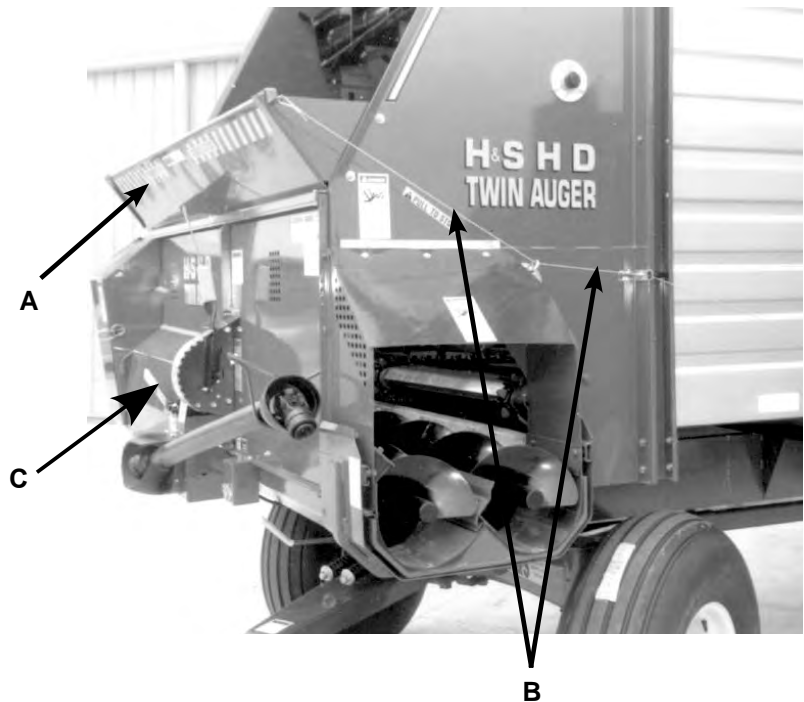

CAP SCREW TORQUE VALUES

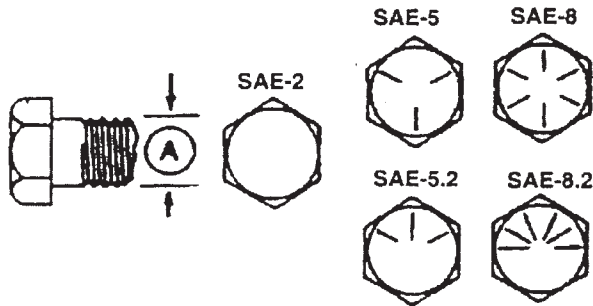

Inch Cap Screw Head Markings

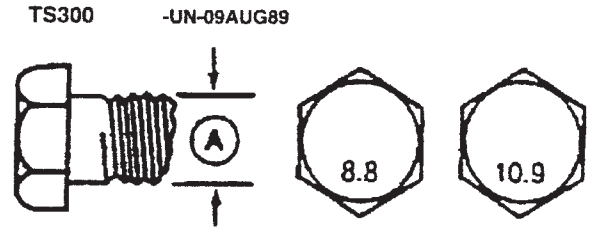

Metric Cap Screw Head Markings

INCH CAP SCREW TORQUE VALUES

METRIC CAP SCREW TORQUE VALUES

Bolt Diameter Wrench (A) Size	Cap Screw Grade							
	SAE 2		SAE 5		SAE 8			
N-m	lb.-ft	N-m	lb.-ft	N-m	lb.-ft	N-m	lb.-ft	
1/4"	7	(5)	11	(8)	16	(12)		
5/16"	14	(10)	23	(17)	33	(24)		
3/8"	24	(18)	41	(30)	54	(40)		
7/16"	41	(30)	68	(50)	95	(70)		
1/2"	61	(45)	102	(75)	142	(105)		
9/16"	88	(65)	142	(105)	203	(150)		
5/8"	122	(90)	197	(145)	278	(205)		
3/4"	217	(160)	353	(260)	495	(365)		
7/8"	224	(165)	563	(415)	800	(590)		
1"	332	(245)	848	(625)	1193	(880)		
1-1/4"	665	(490)	1492	(1100)	2393	(1765)		

Bolt Diameter Wrench (A) Size	Markings on Cap Screw Heads			
	8.8		10.9	
N-m	lb.-ft	N-m	lb.-ft	
5 mm	6	(4.5)	9	(6.5)
6 mm	10	(7.5)	15	(11)
8 mm	25	(18)	35	(26)
10 mm	50	(37)	75	(55)
12 mm	85	(63)	130	(97)
16 mm	215	(159)	315	(232)
20 mm	435	(321)	620	(457)
24 mm	750	(553)	1070	(789)
30 mm	1495	(1103)	2130	(1571)



CAUTION: Use only metric tools on metric hardware. Other tools may not fit properly. They may slip and cause injury.

DO NOT use these values if a different torque value tightening procedure is listed for a specific application. Torque values listed are for general use only. Check tightness of cap screws periodically.

Shear bolts are designed to fail under predetermined loads. Always replace shear bolts with identical grade. Fasteners should be replaced with the same or higher grade. If higher grade fasteners are used, these should only be tightened to the strength of the original.

Make sure fastener threads are clean and you properly start thread engagement. This will prevent them from failing when tightening.

Tighten plastic insert or crimped steel-type lock nuts to approximately 50 percent of amount shown in chart. Tighten toothed or serrated-type lock nuts to full torque value.

SET-UP & ASSEMBLY



WARNING: Some photographs used in the following pages show guards or shields removed for clarification. Never operate machine until these guards or shields are in proper operating position.

NOTE: Determine right or left side of the forage box by viewing it from the rear. If instructions or parts lists call for hardened bolts, refer to the Cap Screw Torque Value page to identify.

1. Check the Forage Box for proper assembly and adjustment. Make sure that all bolts are tightened.
2. Properly lubricate the Forage Box before operating. Refer to Lubrication Section of this Operator's Manual for locations.
3. **GEARBOXES:**
Main Apron Drive Gearbox; Keep the main apron gearbox filled to the oil level plug in cover of gearbox using 85W140 lubricant.

Beater Drive Gearbox; Keep the beater drive gearbox filled to the center of the shafts. Use 80W90 lubricant.
4. Check all lights to make sure that they are functioning properly.

TRANSPORTING

TRANSPORT LIGHTING & REFLECTORS

Transport lighting is standard on all models. The lighting system is to be connected to the 7 pin power receptacle (per SAEJ560B) on your tractor. If your tractor is not equipped with the proper receptacle, see your tractor dealer for details. Red reflective safety decals are on the rear of the box for safety.



WHEN TRANSPORTING ON THE HIGHWAY OR ROADS, PLACE SMV SIGN IN SOCKET PROVIDED AND REGULARLY CLEAN THE REFLECTIVE TAPE AT THE REAR OF THE FORAGE BOX.

NOTE: Obey all state and local laws, concerning towed equipment, on public roads.

TOWING ON HIGHWAY

To view beyond the back of the Forage Box when transporting the unit on a public highway, consider obtaining and installing a rear view mirror on your tractor with a wide load mounting bracket.

PREPARING FOR OPERATION

Check over entire unit carefully before first operation. Tighten bolts, set screws, and chains which may have come loose in handling. Lubricate as explained in the Lubrication Guide. Successful operation will be achieved by periodic adjustments and experience of the operator. Make sure to read and understand all adjustments.

TRACTION CONNECTIONS

PTO Drive

Attach the Forage Box PTO to the tractor PTO shaft locking it into position. Maintain correct distance between the tractor drawbar hitch, tractor PTO and the universal joint at front of unit. This is necessary to prevent overextending the universal joint shaft.

1. Maintain a straight alignment between the Forage Box and the tractor.
2. Maintain a distance of 6"- 12" between the top of the tractor drawbar and the center of the tractor PTO. An 8" distance is standard.

After the correct distance is obtained, depress the locking collar against the spring tension, and slide the yoke onto the tractor PTO shaft. Release the locking collar and move the yoke ahead or back until the lock engages into the groove on the shaft.

NOTE: Do NOT attempt to use a hammer to help in attaching the PTO drive connection.

The tractor drawbar should be adjusted in relation to the tractor PTO shaft as follows:

1. Hitch point of drawbar 14 inches behind tractor PTO shaft.
2. Hitch point of drawbar at least 8 inches, but not more than 14 inches below PTO shaft.
3. Hitch point of drawbar at least 13 inches, but not more than 22 inches above ground level.
4. When unloading, keep the hitch point of the drawbar and PTO shaft in a straight line to the Forage Box. If the PTO is at an angle, it will result in a pounding noise and damage to U joints and the safety clutch.

IMPORANT! DO NOT operate unless 2" minimum extension is maintained.

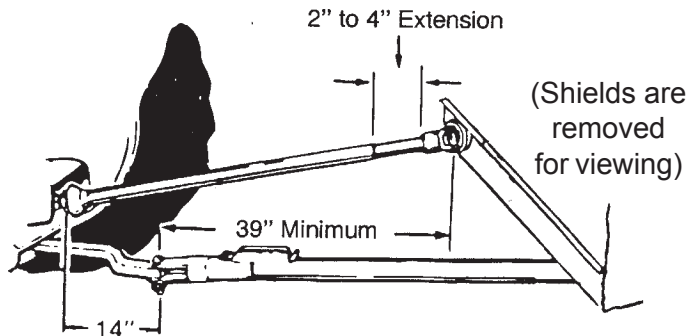

The telescoping PTO drive is designed to rotate freely inside the drive shield tubes. Run the unloading mechanism for several minutes. This will serve as a break-in and as a check that all parts are assembled and lubricated properly.

After you have run the Forage Box for several minutes, check the main apron chains again for proper adjustment, as paint may initially come off the apron chains and chains may loosen. The main apron chains must be taken up evenly before you use the forage box. Check again after the first few loads. The main aprons should be at proper tension at all times. See [Adjustment Section](#) for details.

The Power Take Off Shaft from tractor to box should not be connected for road travel or field operation. Damage may result to the PTO Shaft. A convenient hanger is provided to hold PTO shaft during the time it is not being used to unload.



PREPARING FOR OPERATION

DRIVE - REAR UNLOAD

To operate this forage box as a Rear Unload, the following steps must be followed:

1. Remove the clip pin holding drive pin in front drive sprocket assembly.
Rotate pin counter-clockwise and remove from assembly.
2. Re-insert drive pin into rear drive sprocket
Rotate pin clockwise until it locks into groove on peg.
Secure with clip pin.
3. Adjust rear chain tightener so there is slight deflection at the center of chain.

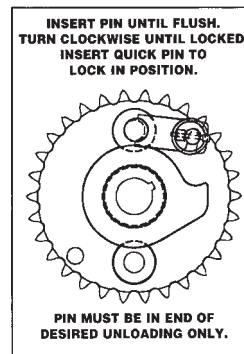
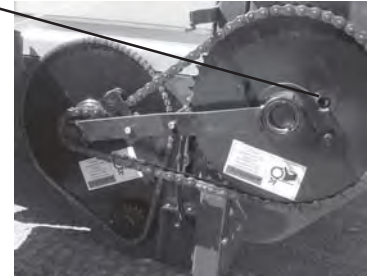
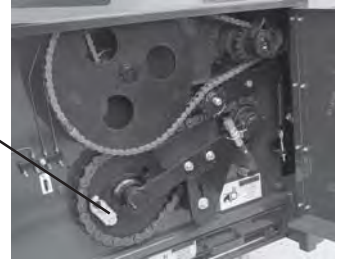

Replace and properly secure all safety shields after making change.

REAR UNLOAD DOOR

Unlock the rear door locks located on the inside of the left and right hand rear drive shaft brackets. Latches lock against knurled gears on rear drive shaft to hold the door closed when operating the forage box as a rear unload. When the tractor hydraulics are activated and the rear drive shaft turns, knurled gears flip latches open to allow rear door to swing free. Upon completion of unloading, check the rear door to insure that latches are securely in place for next load.



CAUTION: Rear door locks should be locked in position only when using front unload. While operating rear unload, rear door locks **MUST** remain unlocked.

FAILURE TO UNLOCK REAR DOOR LOCKS WHEN THE FORAGE BOX IS BEING UNLOADED TO THE REAR WILL RESULT IN SEVERE DAMAGE TO THE FORAGE BOX.

HYDRAULICS - REAR UNLOAD

Attach hydraulic hoses (not supplied) to the metal pipes located below the unloading unit. Install hydraulic couplers compatible with the tractor hydraulic couplers to the hydraulic hose. Attach the hose couplers to the tractor remote.

OPERATION

GENERAL INFORMATION

Check entire Forage Box carefully before first operation. Tighten bolts and set screws that might have come loose in transporting. Lubricate if needed as explained in the Lubrication Chapter in this manual.

EMERGENCY SHUTDOWN

In case of an emergency, pushing the emergency stop panel, emergency stop bar, or pulling the safety cable will stop cross conveyor, beaters, and main aprons. PTO will continue to rotate. If the Forage Box is plugged with material or a foreign object becomes lodged in the discharge area, disengage the PTO. Stop the tractor engine, remove ignition key, and allow all mechanisms to stop before cleaning or working on the machine. Trip emergency stop occasionally to insure proper function.



CONTROLS & SAFETY EQUIPMENT

Forage Boxes are provided with several features for operator safety and convenience.



Emergency Stop Panel

Emergency Stop Cable

The plastic guard protects the operator from accidentally being exposed to the bottom beater at the discharge opening during operation of forage box. Keep this guard in proper position at all times when operating forage box.

Guards & Shields

Whenever possible and without affecting the operation of the Forage Box guards, shields and/or hinged shields have been used on this equipment to protect potentially hazardous areas. In many places, decals are also provided to warn of potential dangers as well as to display special operational procedures.

PTO Shields

Care must be taken to keep male and female driving elements well lubricated and free sliding. The shield surface must be kept dry, as dirt accumulation on them will quickly cause these units to bind and not rotate. If, at any time the shields do not turn freely, they should be checked to determine the cause, and repaired or cleared. DO NOT STEP OVER PTO SHAFT. STAY CLEAR OF ROTATING PTO AT ALL TIMES. DO NOT OVEREXTEND PTO.

OPERATION

OPERATION OF FRONT UNLOAD FORAGE BOX

1. Park the Forage Box on level ground whenever possible during unloading. Lock tractor parking brake
2. Connect the PTO to a tractor with a 540 PTO ONLY, locking securely in place as stated in the PREPARING FOR OPERATION SECTION.

3. Engage PTO

NOTE: Do NOT exceed the rated 540 RPM operating speed of the Forage Box

4. To engage cross conveyor INTERMITTENTLY, rotate clutch lever (A) clockwise and hold with hand pressure. If hand pressure is removed, the cross conveyor will stop.

5. To engage the cross conveyor CONTINUOUSLY, rotate clutch lever clockwise until it locks in the engage position. Cross conveyor speed is controlled by the tractor RPM only.

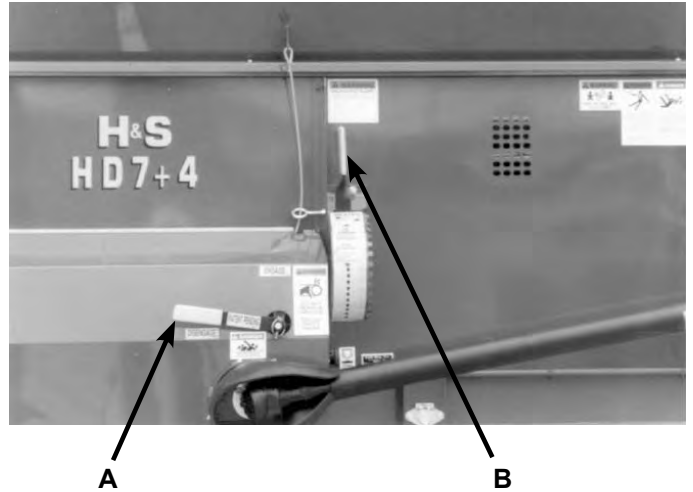

6. Quickly engaging/disengage beater lever will allow beaters to clear material a little at a time to avoid exceeding blower capacity. This single lever controls both beater engage/disengage and the speed of the main feeder aprons. **CAUTION:** DO NOT ENGAGE BEATERS OR MAIN APRONS WHEN CROSS CONVEYOR IS FULL OF MATERIAL OR DAMAGE TO FORAGE BOX WILL RESULT.

7. When beaters are clear of material, move control lever to apron speed position. Variable speed drive offers you a number of unloading speeds to choose from. Rotating the lever downward starts and gradually increases main apron speed. With experience and depending on the type of forage, you will be able to select a speed which will match your blower capacity. Unloading speed may also be varied by increasing or decreasing engine speed of tractor.

8. If it is necessary to trip the stop mechanism and disengage the Forage Box drive before the box empty, restart unloading by engaging clutch lever.

9. Clean out position is for cleaning out the forage box at the end of the load.

10. When the Forage Box is empty, move the control lever to disengage position. **AFTER UNLOADING, ALWAYS RETURN THE CONTROL LEVER TO THE NEUTRAL POSITION WITH PTO RUNNING.**

11. Disconnect the PTO and place it in the convenient holder for field and road use.

OPERATION

OPERATION OF FRONT/REAR UNLOAD FORAGE BOX

1. Park the Forage Box on level ground whenever possible during unloading.
2. Make sure that the drive pin has been changed from front to rear unload as stated in the PREPARING FOR OPERATION - Rear Unload Section.
3. **CAUTION:** Rear door locks must be in unlocked position when set up as rear model as stated in the PREPARING FOR OPERATION - Rear Unload Section.
5. Connect the hydraulic hoses from the Forage Box to the tractor.
6. With operator in the tractor seat and all others well clear of Forage Box, engage tractor hydraulic
Note: Rear unload operates in only one direction. If the tractor hydraulic system stalls, reverse the lever on the tractor or switch the hydraulic hoses at the port on the tractor.
7. During unloading, move the Forage Box forward to allow material to fall way from rear of box.
8. When the Forage Box is empty, disengage tractor hydraulics, disconnect hoses from tractor if detaching the box from the tractor, and securely wrap hoses on convenient holder on the front unloading of unit. If the Forage Box is not going to be detached from the tractor, hoses can stay connected for the next load.
9. Check rear door to make sure it is securely latched.

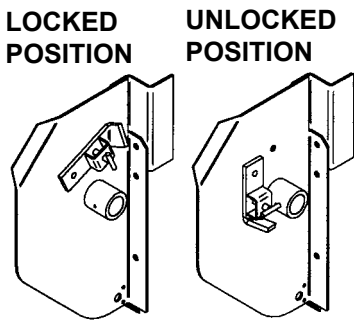

REAR DOOR LOCKS

Located on the inside of the left and right hand rear drive shaft brackets are the rear door locks. These locks should be locked up against rear door frame when forage box is being unloaded toward the front. (LOCK BEFORE LOADING). Door locks must be unlocked (down position) when forage box is being unloaded toward the rear. (UNLOCK BEFORE LOADING).

FAILURE TO UNLOCK REAR DOOR LOCKS WHEN BOX IS BEING UNLOADED TO THE REAR WILL RESULT IN SEVERE DAMAGE TO THE FORAGE BOX.

REAR DOOR LATCHES

Located at the bottom left and right hand side of the rear door are the door latches. These latches lock against knurled gears on rear drive shaft to hold door closed when operating forage box as a rear unload. When tractor hydraulics are activated and rear drive shaft turns, knurled gears flip latches open to allow rear door to swing free. Upon completion of unloading check rear door to insure that door latches are securely in place for next load.

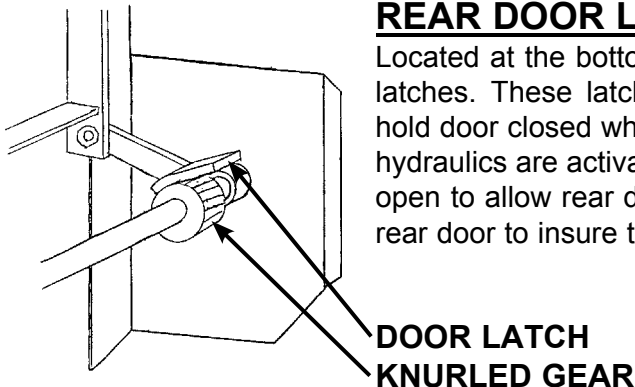

ADJUSTMENTS

MAIN APRON

Four main feeder apron adjustment bolts are located at the rear of the forage box . Two are located at the center of the box and are accessible from below the frame . Left hand tightener bolt is located in panel behind drive shield at left hand corner of box . Right hand tightener and bolt is located in panel at right rear of corner of box.

All apron chains must be taken up evenly before you use the forage box . Check again after the first few loads . The Main Feeder Aprons should be at proper tension at all times . Tighten the full threaded bolts (A) to adjust aprons to approximately . With the 1st apron slat at the rear of the box, the 2nd cross slat inside the box going forward should be able to raise approximately 1" off the floor as shown in the picture at the bottom of the page . When the proper adjustment is reached, replace the hair pin clip in the bolt head . Maintain this tension when operating the box



A

**Left Side Apron
Tightener Bolt**



A

**Right Side
Apron
Tightener Bolt**



A

**Center 2
Tightener Bolts**

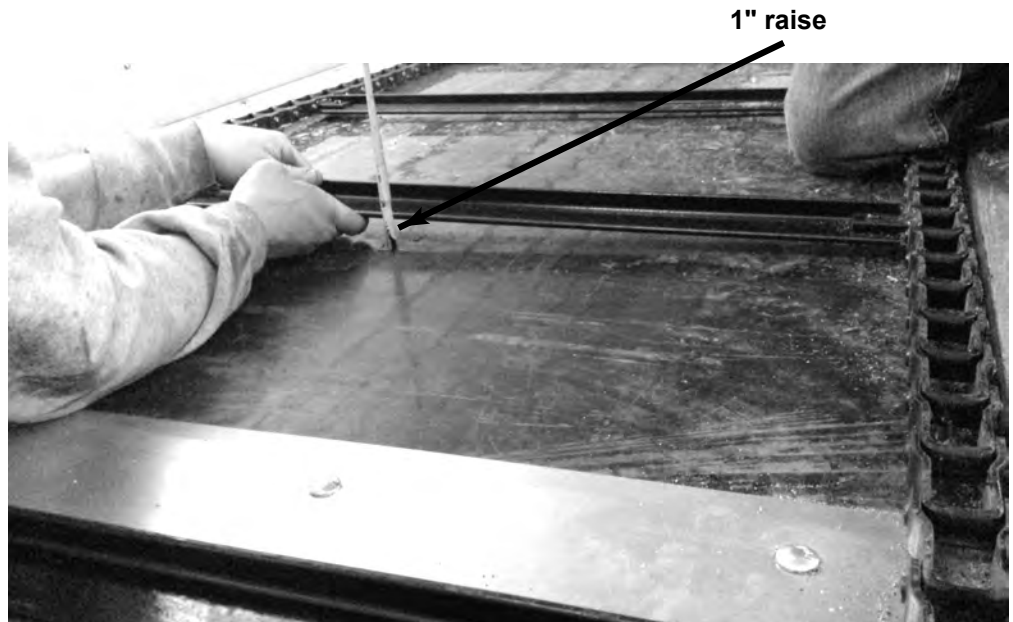

1" raise

ADJUSTMENTS

TWIN AUGERS

Proper tension should be maintained on the auger wipers and hold downs when operating forage box. To adjust wipers and hold downs, start with rear auger first. Loosen bolts (B) holding front wiper on rear auger, and slide wiper against flighting so end of auger can only be raised slightly. Re-tighten bolts. Loosen (C) and slide hold down tight against auger flighting. Re-tighten bolts. To adjust front auger wiper, loosen bolts (D) and slide wiper against flighting of auger so end of auger can only be raised slightly. Re-tighten bolts. Check adjustment of wipers and hold downs periodically.

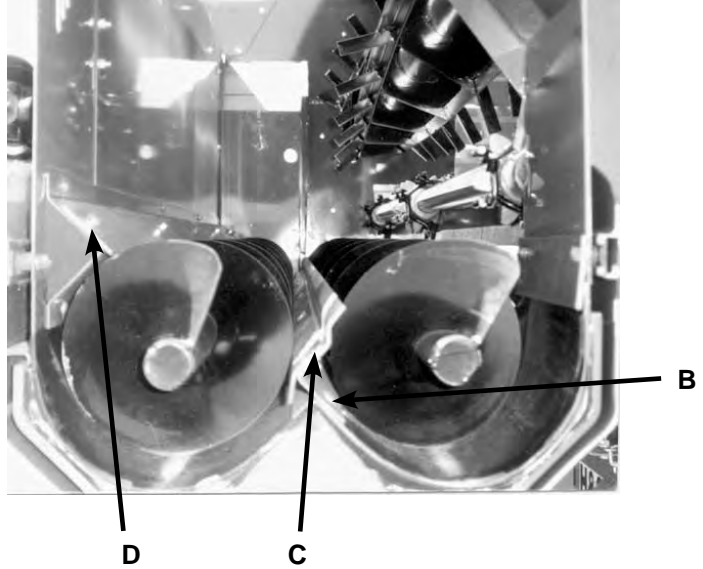

SHEAR BOLTS

The cross conveyor is protected by two shear bolts, located in the drive sprocket and shear hub assembly, located at the right hand end of cross conveyor. Two spare shear bolts are provided. Always determine the cause of failure and eliminate the cause before installing new shear bolts. Use only H&S shear bolts when replacing.

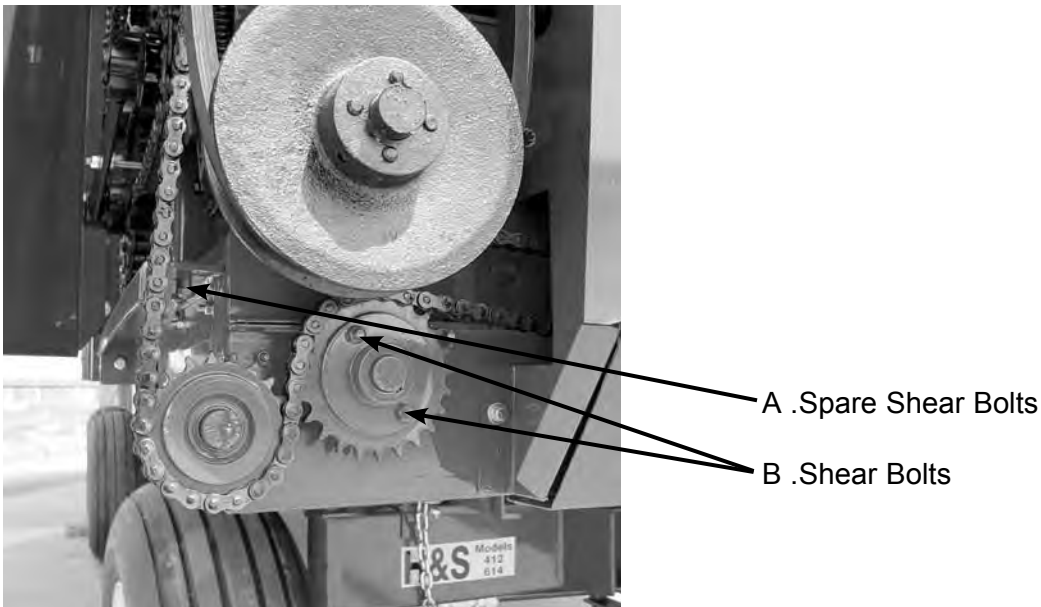

ADJUSTMENTS

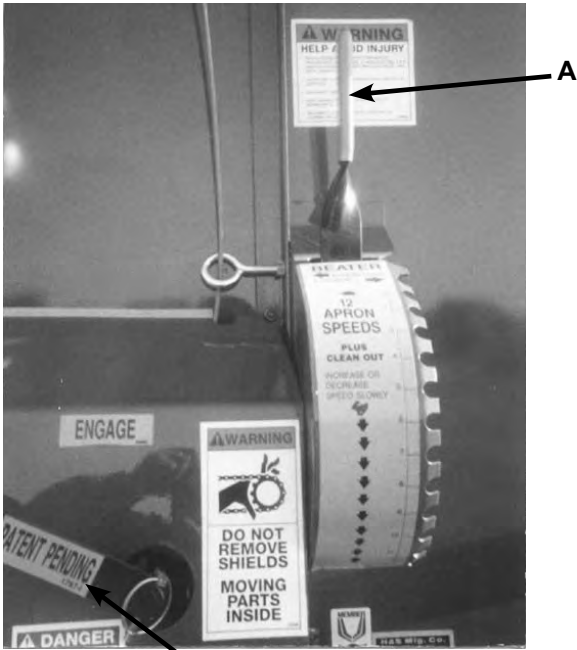

BEATER ENGAGE, APRON SPEED CONTROL LEVER

This single lever (A) controls both beater engage/disengage and the speed of the main feeder aprons. **CAUTION: DO NOT ENGAGE BEATERS OR MAIN APRONS WHEN CROSS CONVEYOR IS FULL OF MATERIAL OR DAMAGE TO FORAGE BOX WILL RESULT.** Prior to engaging beaters and main aprons, intermittently rotate emergency stop lever (B) to the engage position to clear cross conveyor of all material. When beater control lever is engaged, the beaters and main aprons will start at the same time. AFTER UNLOADING, ALWAYS RETURN THE CONTROL LEVER TO THE NEUTRAL POSITION **WITH PTO RUNNING.**

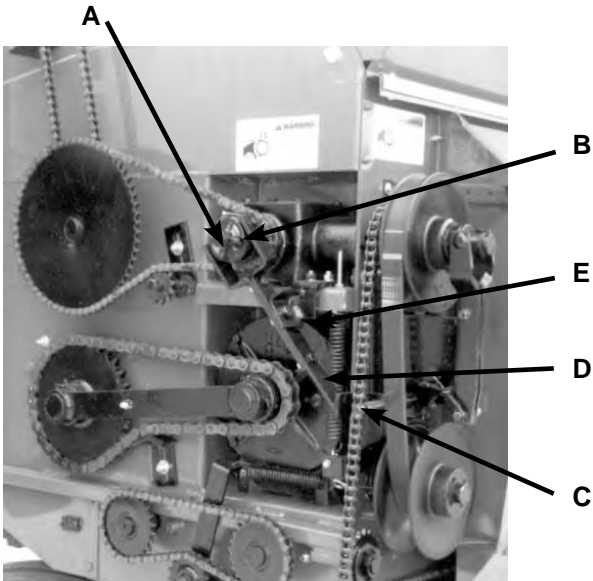

BEATER CLUTCH ADJUSTMENT

Check beater clutch periodically to insure beaters are being completely engaged or disengaged. Beater engage/disengage clutch is properly adjusted when there is 1/8 inch of clearance between clutch jaw (A) and engaging pin (B), when control lever is in the disengage position. Basic adjustment can be made by positioning adjusting nut (C) 2-7/8" from end of control rod. Place control arm (D) tight against nut. Adjust mounting bracket (E) in slotted holes on unit until 1/8" clearance is reached. Fine adjustment is made by adjusting nut (C) on control rod.

VARIABLE SPEED DRIVE BELT

After extended use of forage box, it may become necessary to adjust or replace variable speed drive belt.

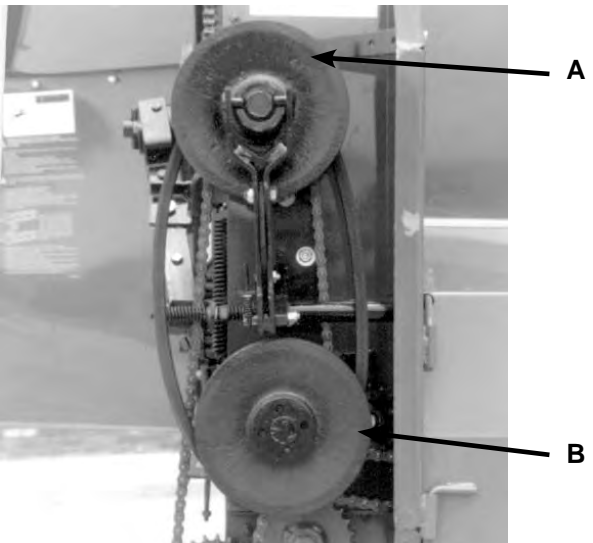

BELT REPLACEMENT

If it becomes necessary to replace the variable speed drive belt, follow the steps listed below to remove worn belt:

1. Place control lever in beater disengage position.
2. Open upper sheaves (A) so belt rests on drive pins.
3. Remove belt from lower sheaves (B) first and then upper sheaves.

Reverse the above steps when installing new belt.

ADJUSTMENTS

VARIABLE SPEED BELT ADJUSTMENT

You should rarely have to adjust the variable speed drive belt. If, however, it becomes necessary to adjust the belt, follow the steps listed below:

1. Remove belt as previously instructed.
2. Move control lever to the highest apron speed position.
3. Check upper sheaves (A), if base of sheaves are not tight together, it is necessary to adjust.
4. Remove bolt from control rod (B).
5. Slide sheaves tight together, being sure control yoke (C) is tight against thrust bearing and sheaves.
6. Adjust control rod (B) so hole in control yoke and rod align, then one additional turn.
7. Replace bolt. Allow sufficient play when tightening, so control rod pivots.
8. Place control lever in beater disengage position and replace the belt.

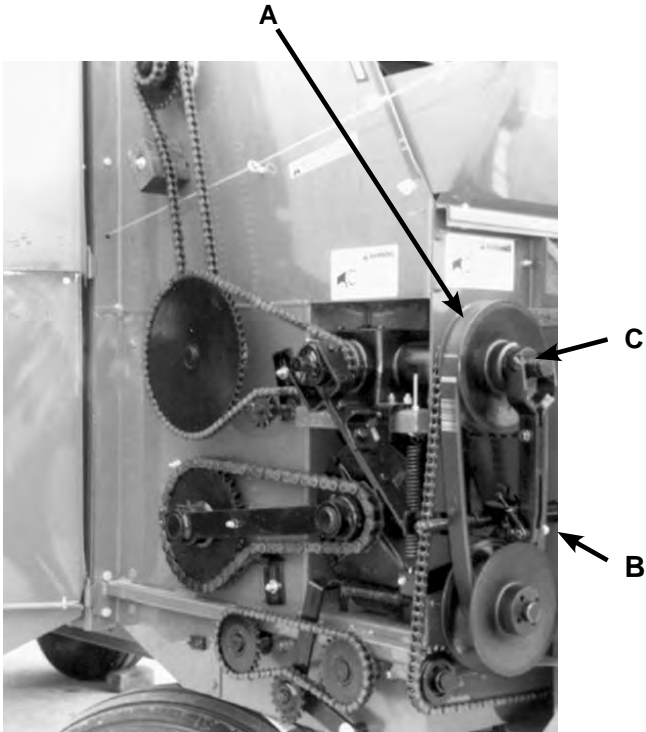

DRIVE CHAIN IDLERS - REAR UNLOAD

The roller chain between hydraulic motor and large reduction sprocket is adjusted by loosening the bolts holding motor. Slide motor downward in slots in panel until chain is tight. Retighten the bolts holding motor.



A roller type chain tightener is provided to adjust tension on roller chain between drive sprocket and main apron drive shaft. Chain is properly adjusted when there is a slight deflection at the center of the chain.



SERVICE

ENTERING FORAGE BOX

Front Unload

If you plan to manually unload the Forage Box utilizing cross conveyor, the following two-man procedure must be followed. **NEVER ATTEMPT THIS PROCEDURE ALONE. THE PERSON OUTSIDE OF FORAGE BOX OPERATING CONTROLS MUST NOT LEAVE CONTROLS.**

1. Place control lever in beater disengage position.
2. Disengage tractor PTO, shut off tractor, and remove the ignition key.
3. Disengage tractor hydraulics, shut off tractor, and remove the ignition key.
4. Remove variable speed drive belt. This will prevent main aprons from moving.
5. Remove connector link from beater drive roller chain and remove chain from sprockets.
CAUTION: BEATERS ARE NOW FREE TO ROTATE
6. Using a short piece of chain with hooks, secure top beater to center beater. See picture below.
7. Wrap chain around bar of third beater and top bar of second beater. Secure chain together as tight as possible to eliminate beaters from rotating in either direction. Keep excess chain out of cross conveyor chamber. **NOTE:** Hook chain properly and securely to prevent unhooking during this procedure.
8. Using extreme caution, the first person may now climb over beaters.
9. When the first person is clear of beaters, second person may start tractor and engage PTO to operate cross conveyor.
10. Before first person attempts to leave forage box, second person must disengage tractor PTO, shut off tractor, and remove the ignition key.
11. When forage box is clear of people, remove safety chain from beaters, re-install drive belt and beater drive chain. Adjust tightener on roller chain.

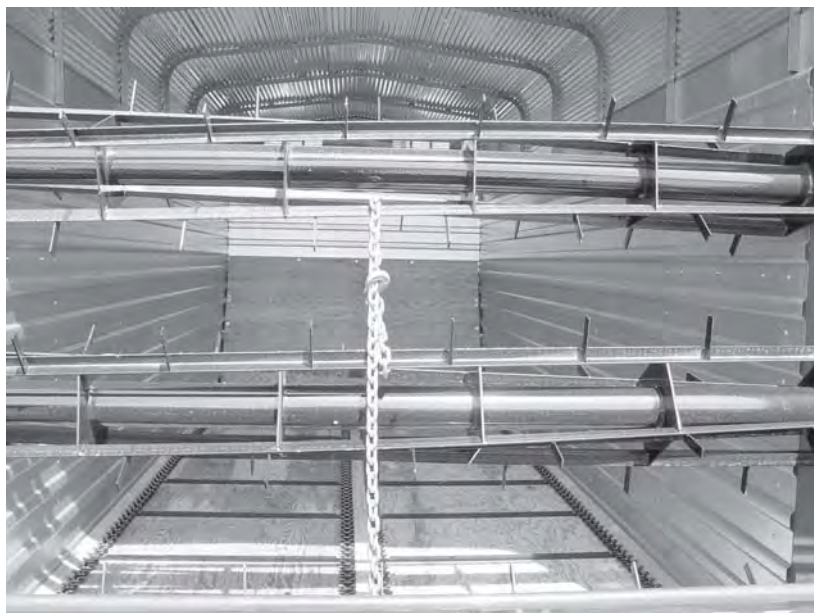

SERVICE

ENTERING FORAGE BOX

Rear Unload

When the Forage Box is empty, entry can be made through rear door. Use the following steps when entering the Forage Box through the rear door.

1. Shut off tractor and remove ignition key.
2. Disconnect PTO and/or hydraulics from tractor and place in appropriate hanger.
3. Securely block rear door open to prevent accidental closure or entrapment.
4. Use a small ladder or similar climbing device to enter the rear of Forage Box.

When the Forage Box is not empty, and entry must be obtained, follow the Front Unload Entry Procedure.

STANDARD SLIDE OUT EXTENSION

Extension slides out for easy access to blower and slides in for road and field travel.



SLID OUT



SLID IN

OPTIONS

HYDRAULIC DRIVE

Hydraulic drive unit easily mounts and dismounts from unit

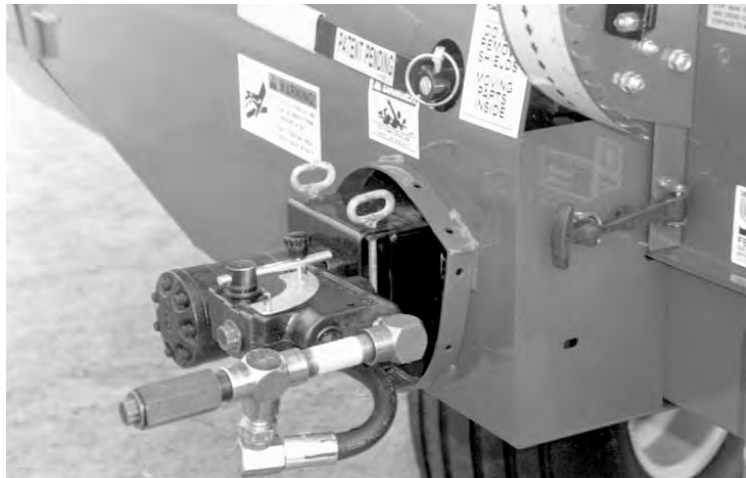

LUBRICATION

GENERAL INFORMATION

IMPORTANT: *Catch and dispose of fluid per local waste disposal regulations whenever service is performed on hydraulic components, valves, cylinders, hoses, etc.*

GREASING

There are numerous grease fittings on the Forage Box. Become familiar with all lubrication points and establish a routine to ensure complete lubrication of the Forage Box. Lubricated properly and often, (every 10 hours) with a high-quality grease, will prolong the life of the forage box. Replace any missing or plugged grease fittings. Wipe dirt from the fittings before greasing to prevent the dirt from being forced into the bearing or pivot. Grease should come out around the shaft on sleeve type bearings. On the sealed ball bearings, grease should be added slowly until a slight bead forms at the seal indicating the correct amount of lubricant. To minimize dirt build-up, avoid excessive greasing. After greasing, wipe off the excess grease from around the outside of the bearings to prevent the accumulation of chaff and grit.

GEARBOXES

Main Apron Drive Gearbox; Keep the main apron gearbox filled to the oil level plug in cover of gearbox using 85W140 lubricant.

Beater Drive Gearbox; Keep the beater drive gearbox filled to the center of the shafts. Use 80W90 lubricant.

DRIVE CHAINS

Lubricate the drive chains with a light machine oil. Keep chains aligned with sprockets, this lengthen the life of the sprockets and chain. Lubricate chains often.

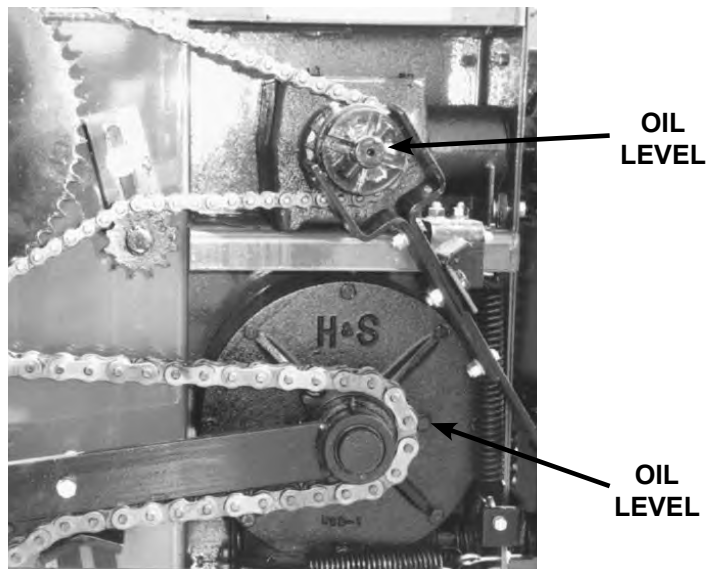

PTO ASSEMBLY

Keep the male and female shafts of the PTO well lubricated and free sliding. Failure to observe this precaution will result in excessive pressure being required to collapse or extend the assembly while subject to operating torque. This excessive force may damage the main shaft bearings. Never lubricate the shield surfaces. The shield surfaces must be kept dry, as dirt accumulation on them will cause the shields to bind and not rotate. Dented or damaged PTO shields, will also result in excessive force being applied against the jackshaft. Damaged shields also cause difficulty when installing the assembly. If at any time the shields do not turn freely, they should be checked to determine the cause, and repaired or cleaned. To avoid damage to the main drive bearings, avoid turning sharp corners while PTO is running. Start and Stop PTO slowly to avoid damage to the drive line.

LUBRICATION

- A. (2) one at each end of PTO at U-joint
- B. (1) one on variable drive outer upper sheave
- C. (1) one on variable drive inner lower sheave
- D. (1) one on beater drive clutch
- E. (1) one on sprocket type chain tightener - beater drive chain
- F. (2) one at each end of brace - gearbox to main apron drive shaft.
- G. (2) remote fittings for right hand and center main apron drive shaft bushings
- H. (6) beater bearings -one at each end of each beater (sealed bearings – DO NOT over grease)
- I. (1) one on left hand main apron drive shaft bushing
- J. (8) one on each main apron rear idler sprocket
- K. (1) one on beater engage bronze yoke
- L. (1) one on drive shaft end of brace for rear main apron drive shaft
- M. (1) one on gear reduction sprocket at rear of forage box
- N. (3) one on left, center and right hand rear drive shaft brackets
- O. (1) one on cross conveyor, drive belt tightener (under shield)
- P. (1) one on cross conveyor clutch control handle (under shield)

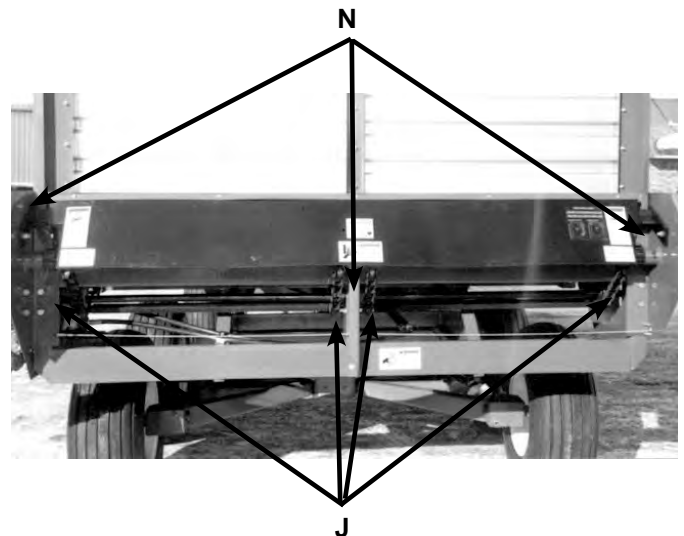
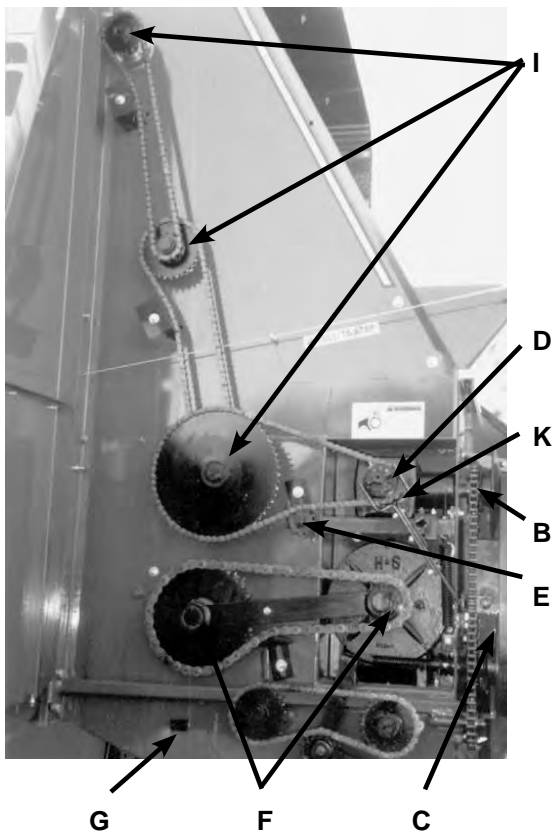
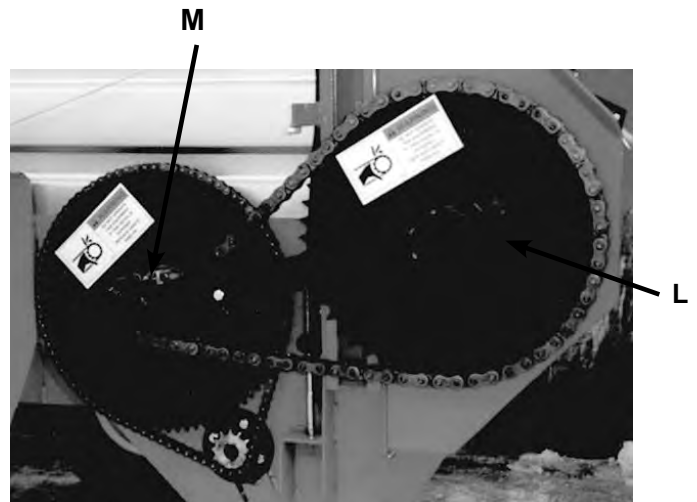
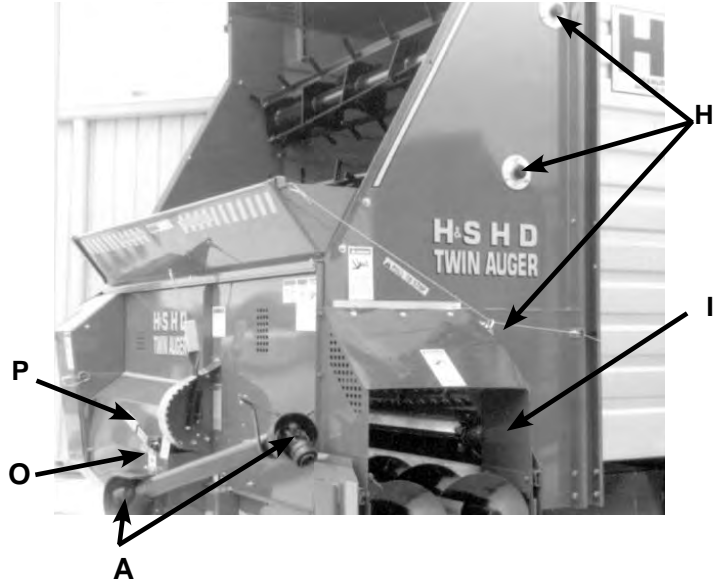

DECAL LOCATION

Your H&S Forage Box was manufactured with operator safety in mind. Located on the Forage Box are various decals to aid in operation, and to warn of danger or caution areas. Pay close attention to all the decals on your Forage Box.



DO NOT REMOVE ANY OF THESE DECALS. IF DECALS ARE LOST, DAMAGED, OR IF FORAGE BOX IS REPAINTED, REPLACE DECALS. REMEMBER: DECALS ARE FOR YOUR PROTECTION AND SAFETY.

Listed below are the decals on your Forage Box. These decals may be ordered individually by part number or by ordering a complete set.

ITEM	PART NO.	DESCRIPTION
A	1494A	Warning - Do Not Operate
AA	1494F	Danger - Never Enter
B	1494K	Warning - Do Not Remove Shields
BB	2495	Warning - Keep Children Away
C	1494Q	Warning - Operator Position
CC	11599	Warning - Stay Clear of Hydraulic Lines
D	1494B	Warning - Do Not Remove Shields
DD	5896C	Warning - Emergency Stop Re-Set
E	5896B	Danger - Rotating Drive-line
G	1191	Beater Engage/Disengage
H	7+42191	Clean Out
HH	31300	Drive Pin - Instructions
I	1494P	Danger - Stay Clear of Power Lines
J	1494L	Danger - PTO
JJ	5696E	Engage
K	DCAMB	Amber Reflector
KK	5696D	Disengage
L	1494H	Danger - Stay Clear
LL	093366	Manual Holder
M	56713	Warning - Help Avoid Injury
MM	093020	Grease Gun
N	1043185	Push This Panel
O	1033185	Emergency Stop
P	1202177	Pull to Stop
R	DCRED	Red Reflector
S	1494C	Warning - Moving Parts Under
T	56842	Entering Forage Box
U	53102	Door Locks
V	1494O	Warning - Emergency Stop Function
W	1494I	Danger - Keep Out
X	1494J	Warning - Do Not Work or Clean...
Y	311	Patent Numbers

DECAL LOCATION

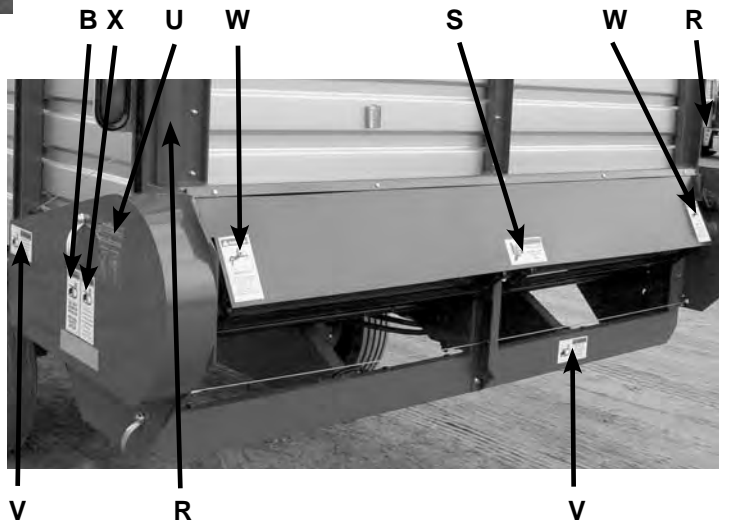
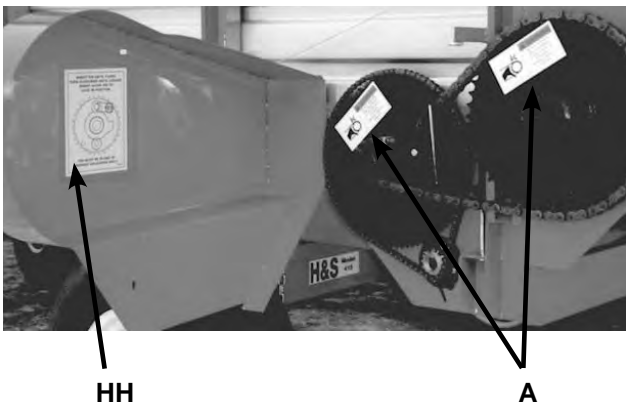
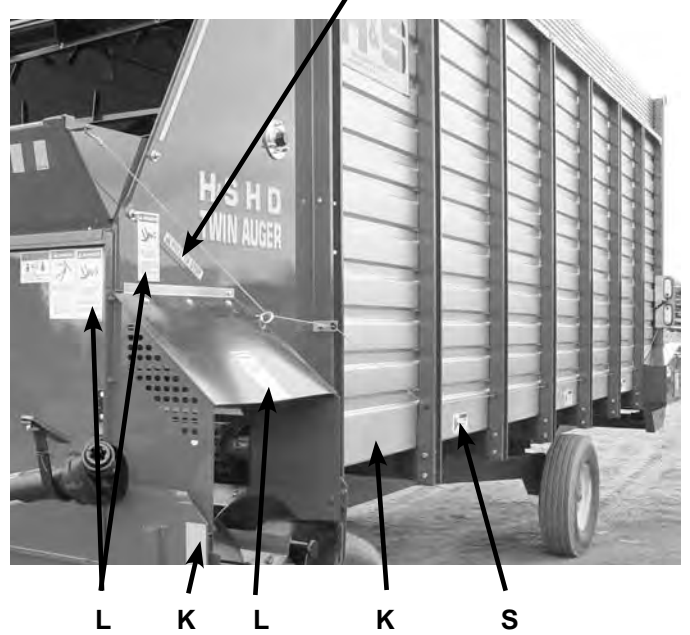
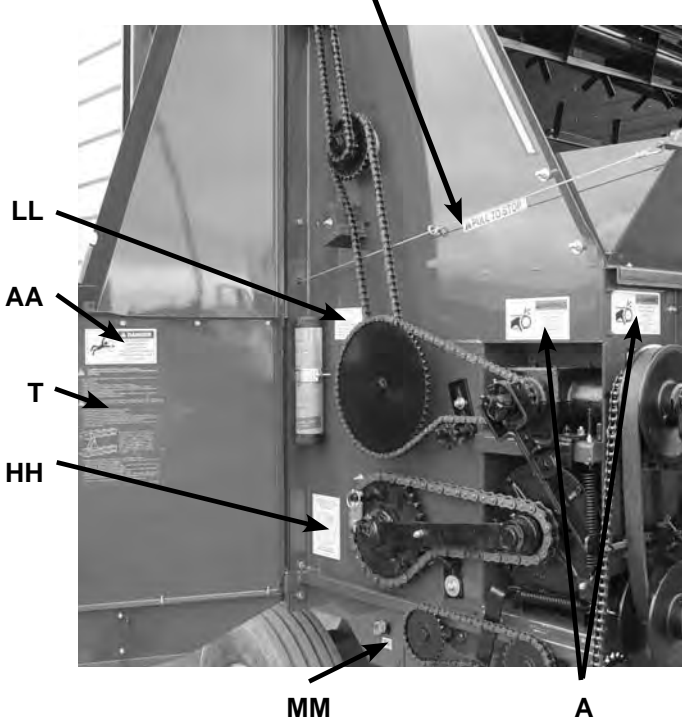
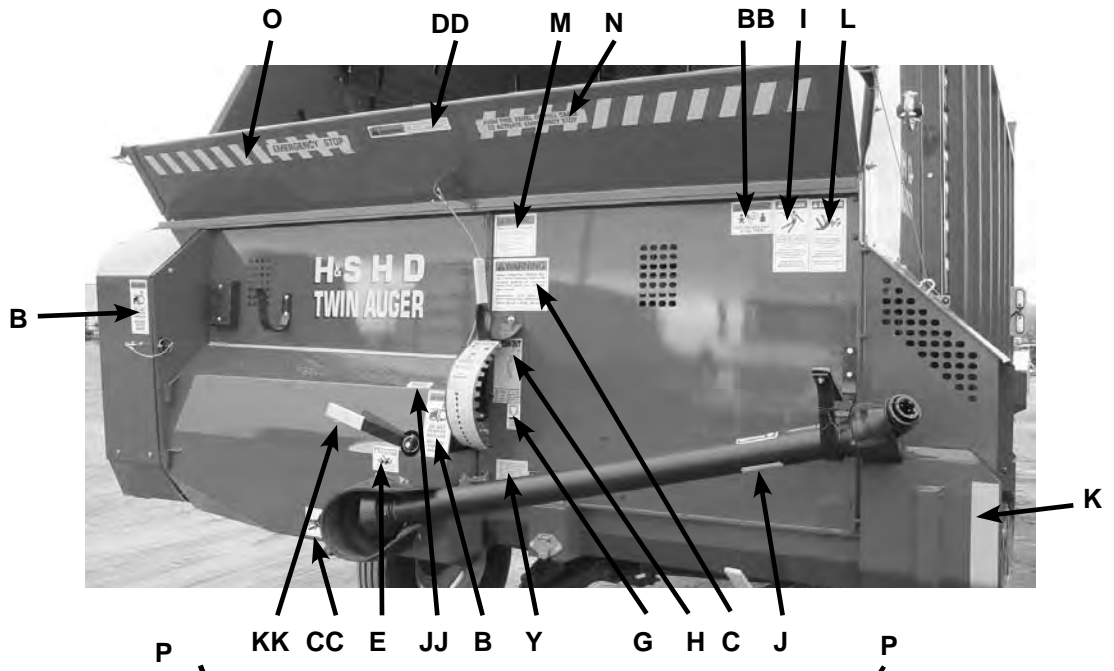

INSTRUCTIONS FOR ORDERING PARTS

All service parts should be ordered through your authorized H&S dealer. They will be able to give you faster service if you will provide them with the following

1. Model & Serial number is located in the front center of the box.
2. All reference to left or right apply to the Super Duty as viewed from the rear.
3. Parts should not be ordered from illustration only. Please order by complete part number.
4. If your dealer has to order parts - give shipping instructions:

VIA truck - large pieces (please specify local truck lines)

VIA United Parcel Service (include full address)

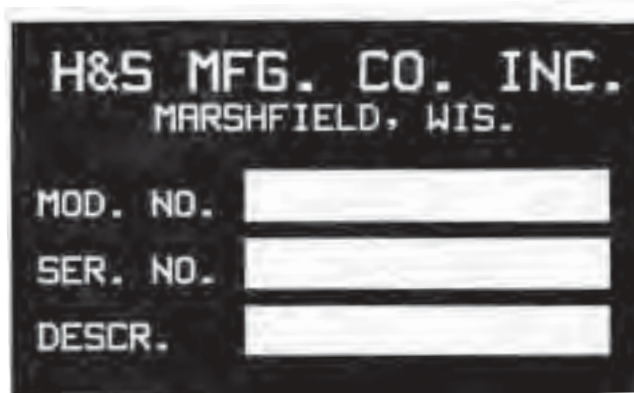

H&S MFG. CO. INC.
MARSHFIELD, WIS.

MOD. NO.

SER. NO.

DESCR.

PLEASE RECORD NUMBERS FOR YOUR UNIT FOR QUICK REFERENCE

ABOUT IMPROVEMENTS

H&S IS CONTINUALLY STRIVING TO IMPROVE IT'S PRODUCTS

We must therefore, reserve the right to make improvements or changes whenever it becomes practical to do so without incurring any obligation to make changes or additions to the equipment previously sold.

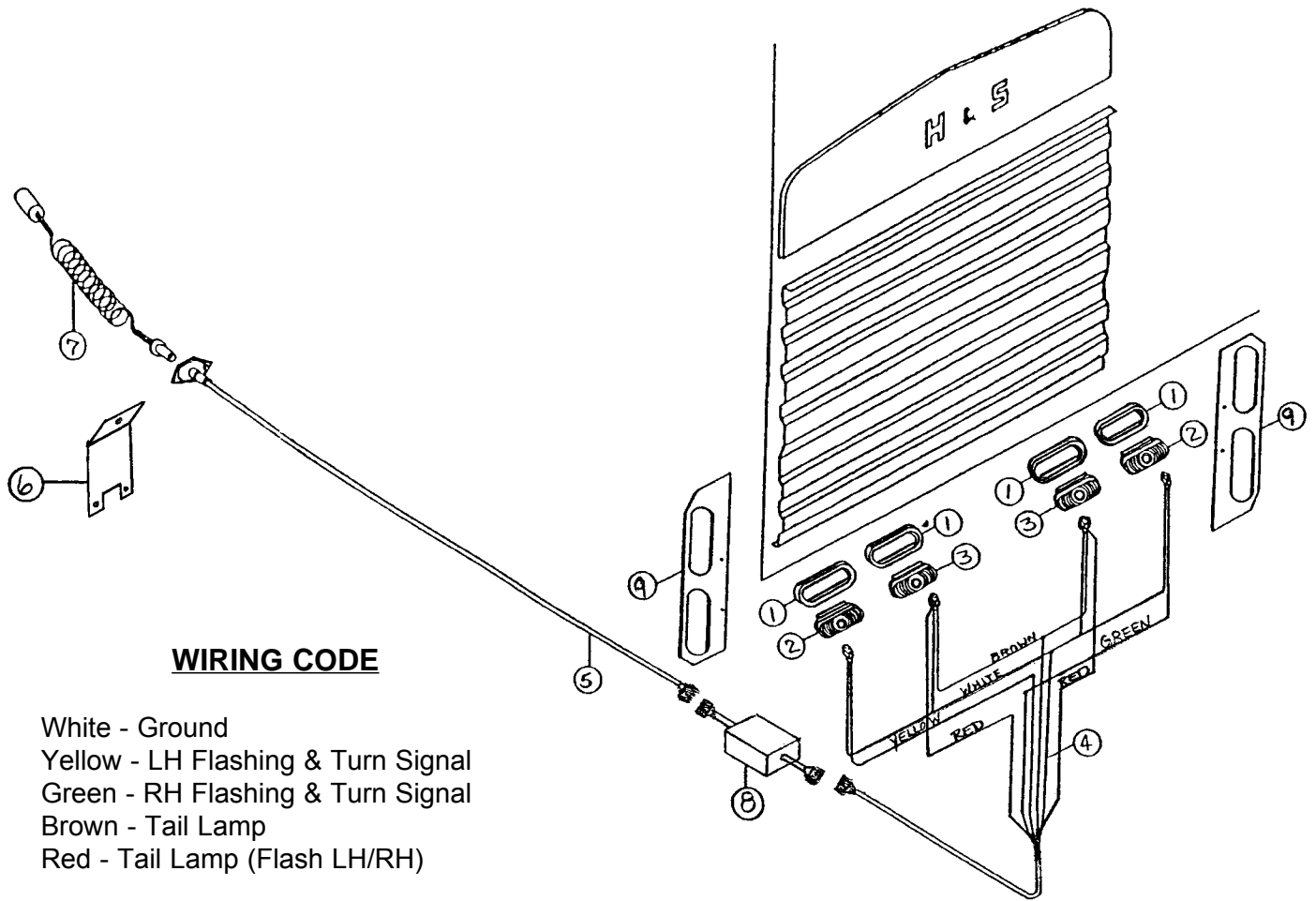

WIRING CODE

- White - Ground
- Yellow - LH Flashing & Turn Signal
- Green - RH Flashing & Turn Signal
- Brown - Tail Lamp
- Red - Tail Lamp (Flash LH/RH)

FIGURE 1
H D 7+4 TWIN AUGER FRONT & REAR
SELF-UNLOADING FORAGE BOXES
LIGHT ASSEMBLY

ITEM	PART NO.	DESCRIPTION
1.	S308	Rubber Light Mount
2.	S309	Amber Light
3.	S310	Red Light
4.	PB232	Light Harness (6-WIRE)
5.	S443	16' Longitudinal Cord (4-WIRE)
*	S442	18' Longitudinal Cord (4-WIRE)
*	S439	20' Longitudinal Cord (4-WIRE)
6.	S346	Mounting Bracket
7.	S317	Optional Tractor Cord
8.	69908	Light Module
*	PB239	16' Complete Light Assembly Less Optional Tractor Cord
*	PB240	18' Complete Light Assembly Less Optional Tractor Cord
*	PB241	20' Complete Light Assembly Less Optional Tractor Cord
9.	PB111	Tailight Brackets

NOTE: * (Means Not Shown)

FIGURE 2

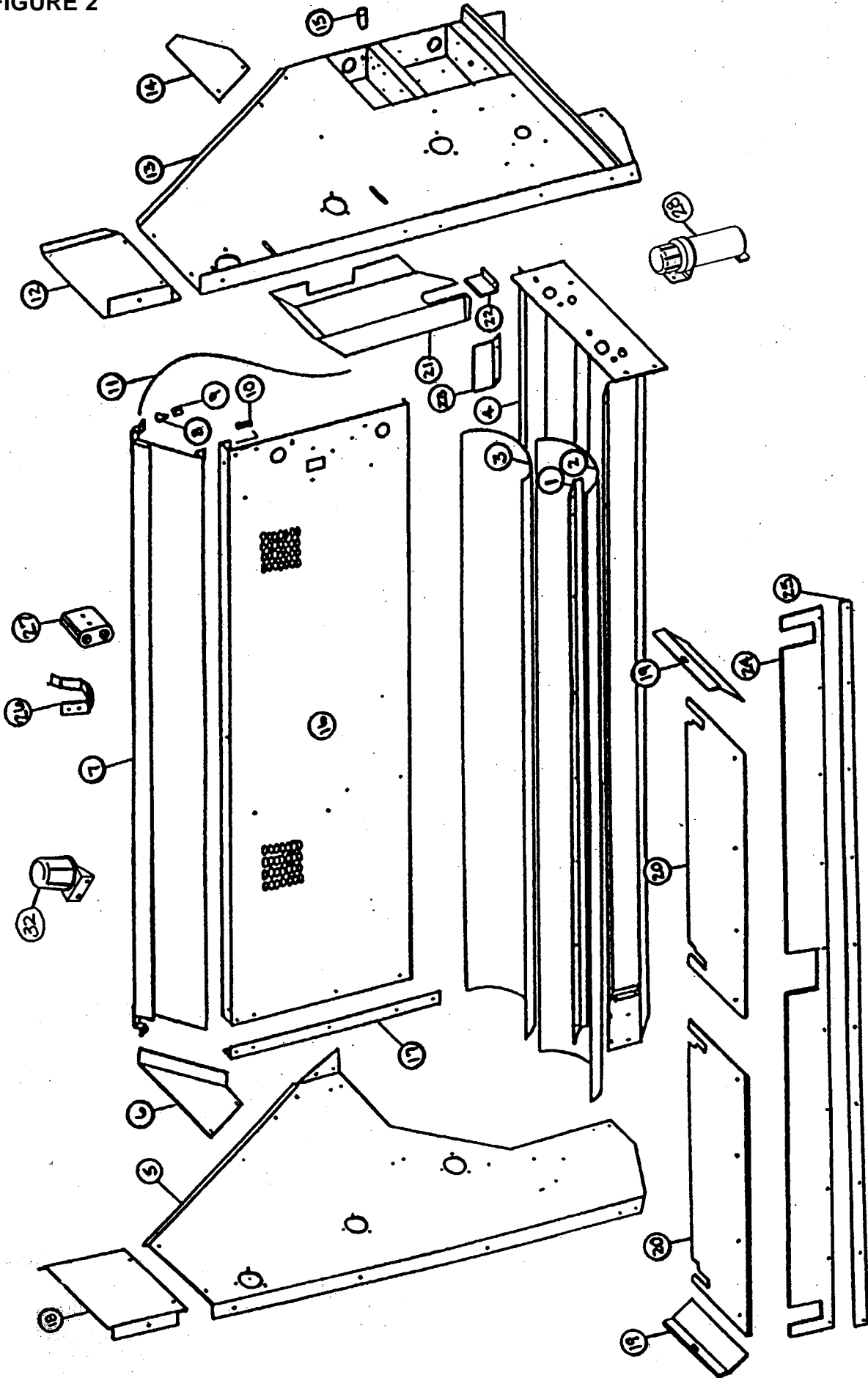

**FIGURE 2
HOUSING COMPONENTS FOR UNIT**

ITEM	PART NO.	DESCRIPTION
1.	ST82	Poly Hold Down and Seal Holder
2.	ST2	Poly Liner for Rear Auger
3.	ST3	Poly Liner for Front Auger
4.	ST83	Auger Housing
5.	S4	LH Side Panel
6.	S5	LH Emergency Stop Panel
7.	S370	Emergency Stop Panel
8.	ES14	Thimble (2)
9.	ES15	Cable Clamp (2)
10.	S7	Spring for Emergency Stop
11.	S8	Emergency Stop Cable
12.	S9	RH Side Panel Top
13.	ST5	RH Side Panel
14.	S11	RH Emergency Stop Panel
15.	S12	Gearbox Brace
16.	ST84	Front Main Panel
17.	ST7	LH Front Angle
18.	S3	LH Side Panel Top
19.	S20	Apron Side Spacer
20.	IFB56	Drive Shaft Panel
21.	ST66	Auger Drive Shield
22.	ST9	Auger Chain Shield
23.	ST67	Wiper End
24.	ST306	Rubber Seal
25.	S288	Rubber Seal Strap
26.	PB79	Hydraulic Hose Holder
27.	JB105	Hose Coupling Holder
28.	S522	Manual Holder
32.	CHM38	Plug Storage

FIGURE 3

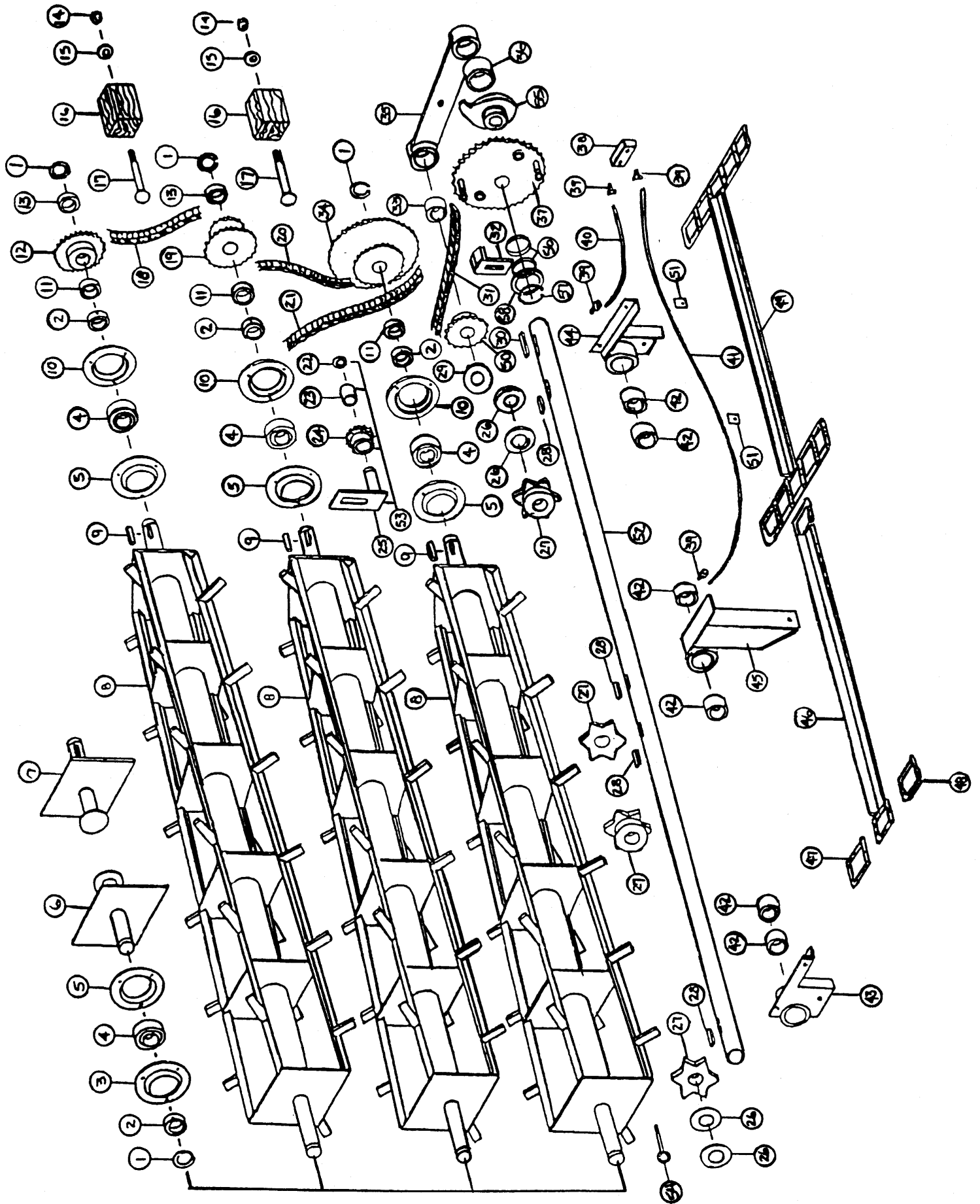

FIGURE 3
BEATERS AND MAIN APRON DRIVE

ITEM	PART NO.	DESCRIPTION
1.	F73	Snap Ring
2.	F16	Lock Collar
3.	F114	Bearing Flange w/Zerk
4.	F115	Bearing Greaseable Type
5.	F14	Bearing Flange
6.	S23	LH Beater Stub Shaft
7.	S24	RH Beater Stub Shaft
8.	S25	Beater
9.	G23	5/16" x 1-3/8" Square Key
10.	F114A	Bearing Flange w/Zerk 45 Degree
11.	S218	3/8" Spacer
12.	S26	3rd Beater Sprocket 20T
13.	S219	1/4" Spacer
14.	K60	Nut
15.	X67	Washer
16.	S27	Wood Chain Tightener
17.	S28	Carriage Bolt 3/8" x 3-3/4"
18.	X58	2nd to 3rd Beater Chain 89 Pitches #50
19.	S30	2nd Beater Sprocket 30T - 13T
20.	S31	1st to 2nd Beater Chain 98 Pitches #50
21.	X58	Beater Drive Chain 89 Pitches #50
22.	10R32	Snap Ring
23.	S33	Chain Tightener Bushing
24.	S34	Tightener Sprocket w/Bushing
25.	L10R35	Chain Tightener Bracket
26.	S36	Drive Shaft Spacer
27.	S37	Apron Drive Shaft Sprocket
28.	S436	3/8" x 1-1/2" Square Key
29.	S327	Poly Gearbox Washer
30.	S38	3/8" x 2-3/8" Square Key
31.	ST10	Apron Drive Chain 56 Pitches #80
32.	S40	Chain Tightener
33.	S41	Bushing
34.	S42	1st Beater Sprocket 60T-20T
35.	S43	Drive Shaft Brace
36.	S44	Bushing
37.	PB192	Apron Drive Sprocket 30T
38.	S46	Grease Line Bracket
39.	S47	Grease Line Fitting
40.	S48	Short Grease Line
41.	S49	Long Grease Line
42.	S50	Drive Shaft Bushing
43.	S51	LH Drive Shaft Bracket
44.	S52	RH Drive Shaft Bracket
45.	S53	Center Bearing Bracket
46.	S233	667H Pintle Slat with Attachment Links
47.	11S51	667H Pintle Connector Link
48.	11S50	667H Pintle Attachment Link RH or LH
49.	S324	667H Complete Pintle Apron 16'
*	S325	667H Complete Pintle Apron 18'
*	S326	667H Complete Pintle Apron 20'
50.	ST11	Worm Gear Shaft Sprocket 13T
*	S66	Slow Down Sprocket 11T
51.	S67	Grease Line Clip
52.	S68	Main Apron Drive Shaft
53.	S216	Chain Tightener Assembly
54.	BFR319	"I"-Bolt 3/8" x 2-1/2"
55.	PB117	Front Clutch Dog
56.	PB135	Bushing
57.	23N227	Snap Ring
58.	PB126	Clutch Sprocket Washer

NOTE: * (Means Not Shown)

FIGURE 4

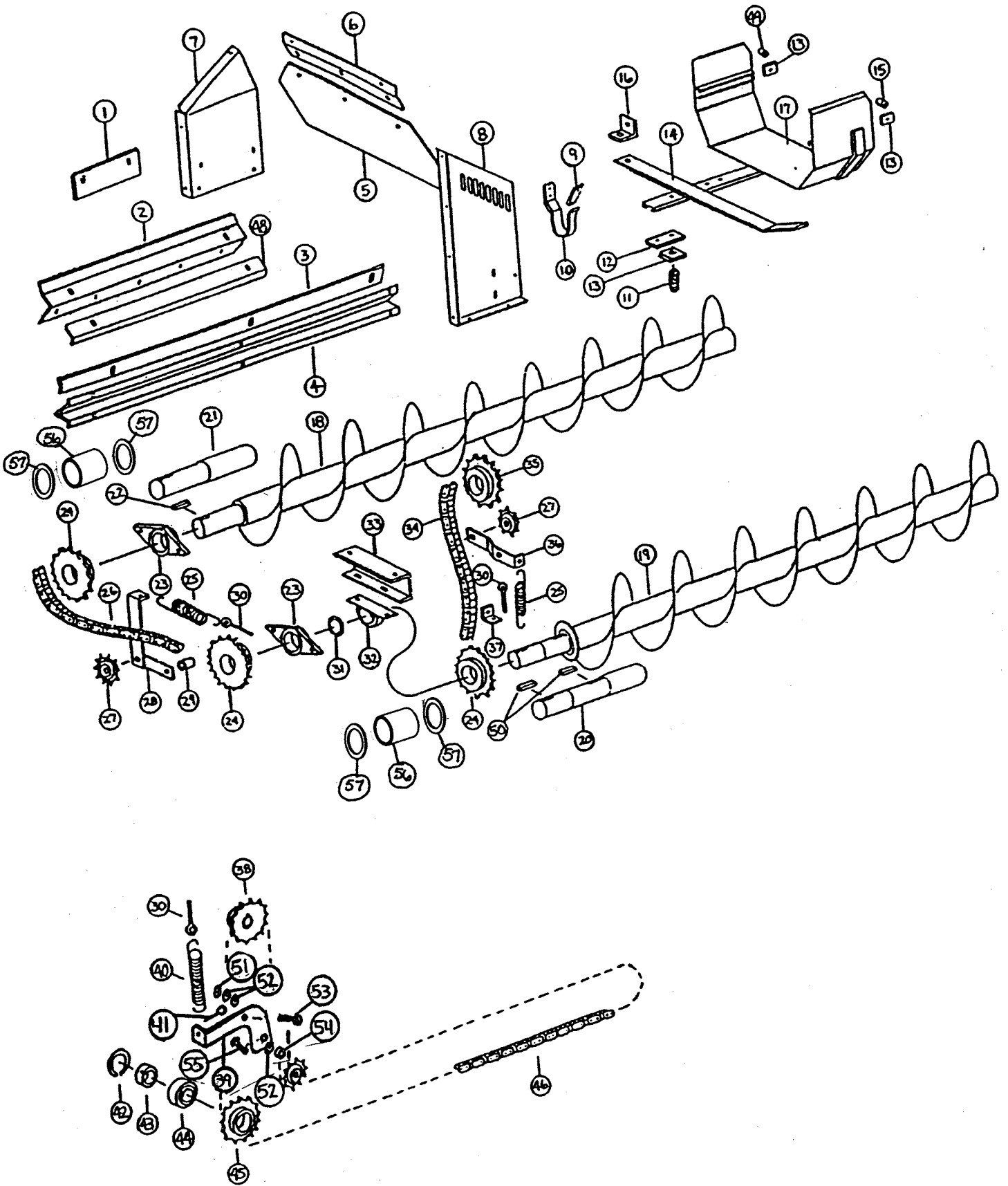

FIGURE 4
AUGERS AND DRIVE COMPONENTS

ITEM	PART NO.	DESCRIPTION
1.	ST68	Poly Hold Down
2.	ST69	Auger Center Wiper
3.	X83	Wiper Blade
4.	ST14	Front Wiper Blade Holder
5.	ST15	Poly Shield
6.	ST16	Poly Shield Bracket
7.	ST17	Extension Panel Rear
8.	ST18	Extension Panel Front
9.	S78	PTO Holder Rubber Tab
10.	S354	PTO Holder
11.	S7	Spring
12.	ST19	Bottom Poly Slide
13.	ST20	Poly Slide
14.	ST21	Handle for Extension
15.	ST81	Spacer
16.	ST22	Angle
17.	ST23	Extension Shell
18.	ST24	Rear Auger
19.	ST25	Front Auger
20.	ST26	Front Auger Stub Shaft
21.	ST27	Rear Auger Stub Shaft
22.	G23	5/16" x 1-3/8" Key
23.	12N29	Bearing
24.	ST28	Sprocket
25.	R27	Spring
26.	ST29	#50 Roller Chain 61 Pitch
27.	K101	Tightener Sprocket
28.	ST30	Tightener Bracket
29.	L12R22	Spacer
30.	ES10	5/16" x 3" I-Bolt
31.	F73	Snap Ring
32.	12N36	Bearing Assembly
	12N33	Bearing
	12N34	Bearing Cover
	12N35	Bearing Holder
33.	ST63	Auger Bearing Bracket
34.	X58	#50 Roller Chain 89 Pitch
35.	ST59	Sprocket 20T
36.	ST32	Tightener Bracket
37.	ST33	Angle
38.	S82	24T Sprocket
39.	S459	Tightener Bracket
40.	ST36	Spring
41.	K79	I-Bolt
42.	K92	Snap Ring
43.	4C9	Lock Collar
44.	K90	Bearing
45.	K89	Idler Sprocket 20T
46.	ST85	#50 Roller Chain 183 Pitch
48.	ST72	Center Wiper
49.	ST77	3/8" Spacer
NOT SHOWN	X60	#50 Offset Link
NOT SHOWN	X61	#50 Connector Link
50.	WM121	Square Key 5/16" x 1"
51.	A34	Washer 1/2"
52.	S468	Washer
53.	16SV126	Counter Sunk Bolt 2"
54.	R65	Spacer 3/8"
55.	S467	Counter Sunk Bolt 2-1/4"
56.	ST92	Conduit Spacer
57.	ST93	Auger Spacer Washer

FIGURE 5

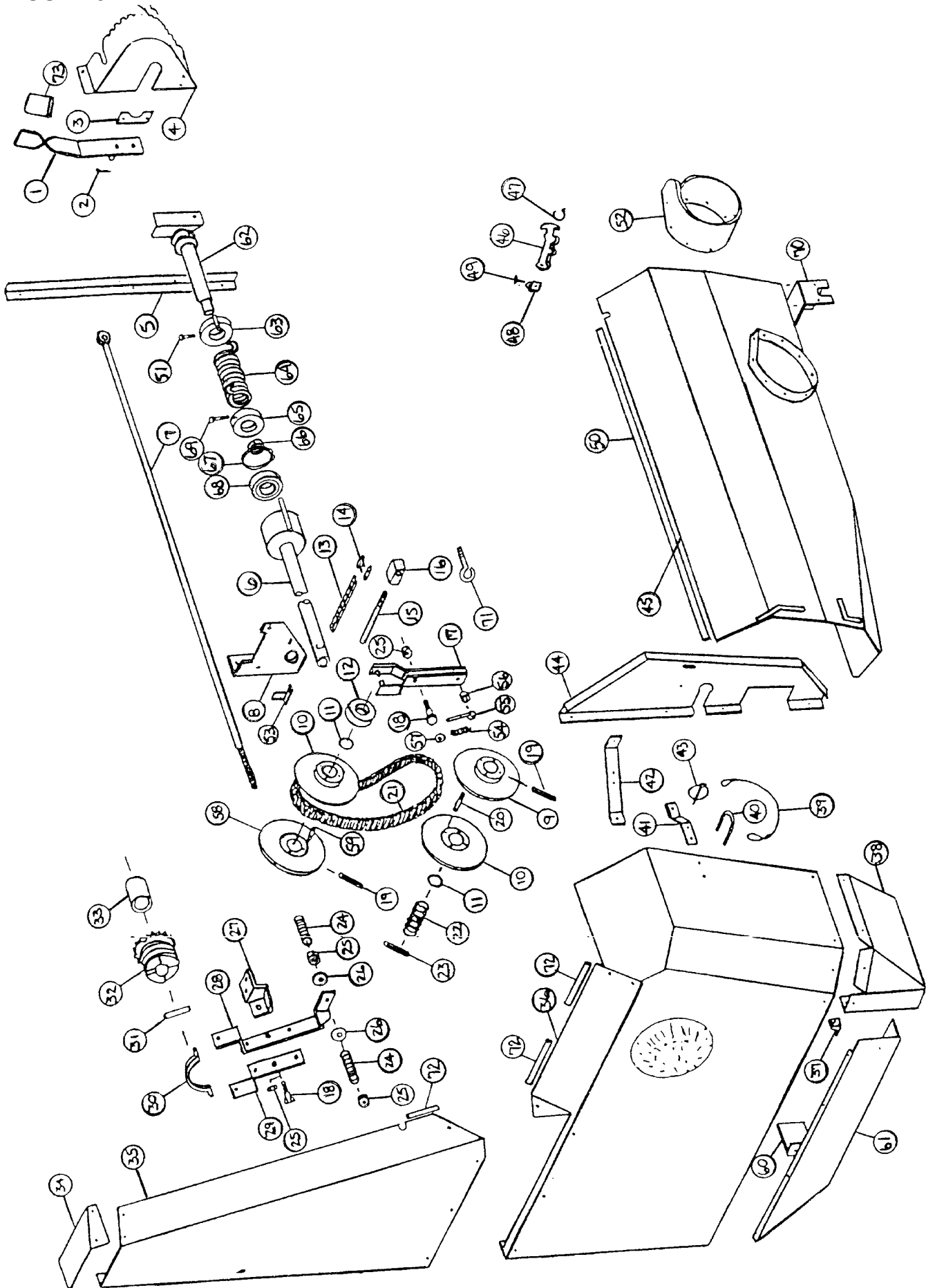
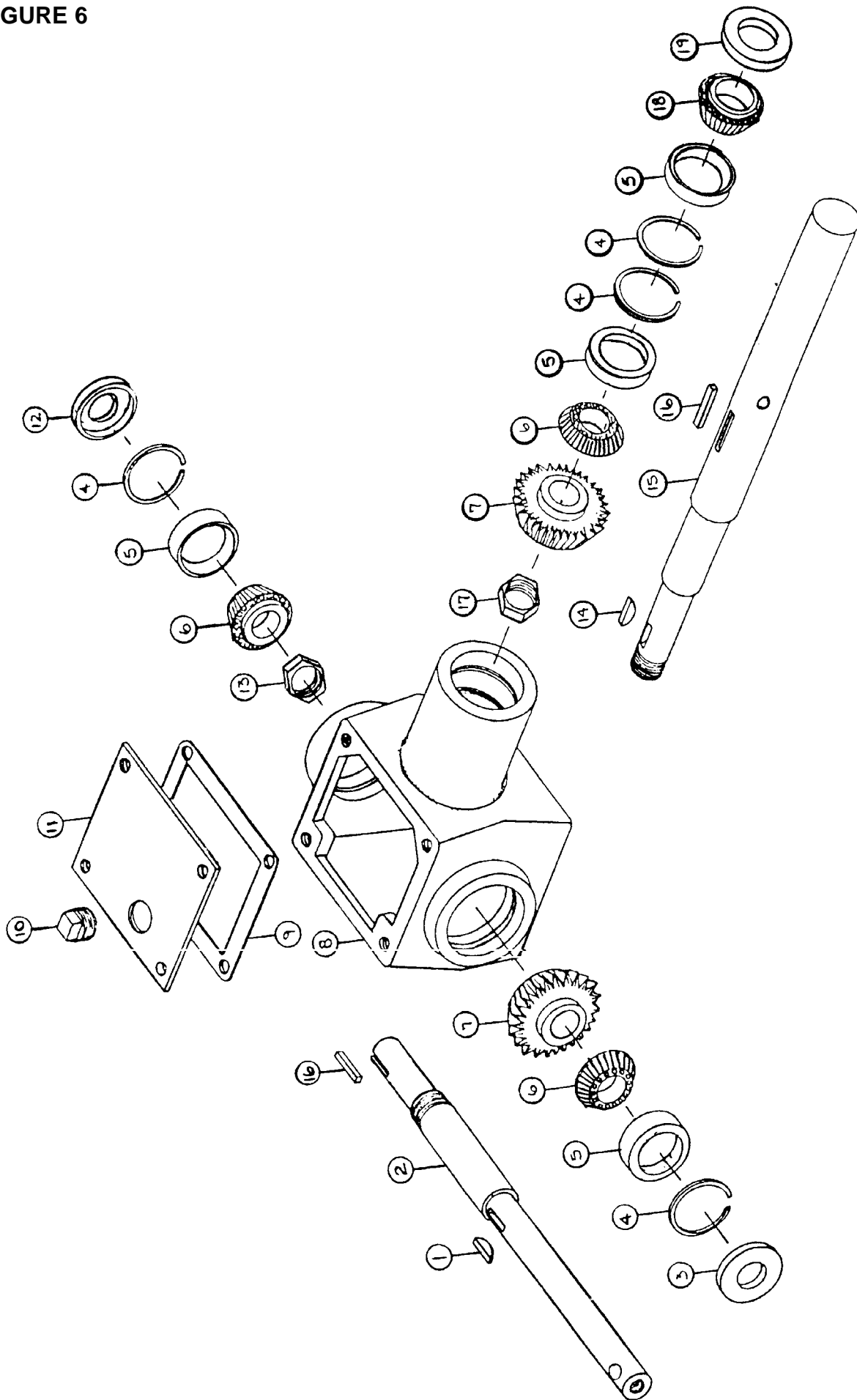

FIGURE 5
SHIELDS - BEATER CLUTCH - BELT DRIVE

ITEM	PART NO.	DESCRIPTION	ITEM	PART NO.	DESCRIPTION
1.	S364	Shifter Handle	38.	ST40	Side Shield Bottom
2.	X43	Cotter Pin	39.	S122	Clip Pin Cable
3.	S91	Shifting Pipe Bracket	40.	F32	U-Bolt
4.	S360	Speed Selector Panel	41.	S123	Shield Latch Bracket
5.	S365	Front Center Angle	42.	S234	Shield Brace
6.	S366	Shifting Pipe (Apron)	43.	F56	Clip Pin
7.	S367	Shifting Rod (Beater)	44.	ST86	Front Upright Shield
8.	S96	Shifting Bracket	45.	S334	Front Shield
9.	S97	Stationary Sheave	46.	X192	Front Shield Latch (Rubber)
10.	S295	Sliding Sheave	47.	X193	Latch Catch Bracket
11.	S99	O-Ring	48.	X194	Latch Mounting Bracket
12.	S100	Thrust Bearing	49.	X195	Pin
13.	S101	#40 Chain 5 Pitch	50.	S359	Plastic Edging 38"
14.	S102	#40 Connector Link	51.	X111	Bolt 3/8" x 1" GR.5
15.	S103	Linkage Rod	52.	S131	PTO Rubber Shield
16.	S104	Adjustment Block	53.	S221	Spring Shift Bracket
17.	S105	Variable Speed Shifter	54.	S222	Shifting Spring
18.	R10	1/2" x 1-1/4" Bolt GR.5	55.	S220	Shifting Spring Rod
19.	S106	5/16" x 2-3/4" Expansion Pin	56.	K94	Spacer
20.	S296	Sheave Pin	57.	T16	1/4" Flat Washer
21.	S108	Variable Speed Belt	58.	S97	Sheave
22.	S109	Spring	59.	S296	Sheave Pin
23.	S110	1/4" x 2" Expansion Pin	60.	ST45	Inside Shield
24.	S111	Spring	61.	ST39	Lower Side Shield
25.	9S17	1/2" Lock Nut	62.	S290	Shifter Pipe Handle End
26.	S285	Beater Clutch Washer	63.	S291	Spring Pin Collar
27.	S112	Beater Clutch Bracket	64.	S292	Spring
28.	S113	Beater Clutch Long Arm	65.	S293	Spring Collar
29.	S114	Beater Clutch Short Arm	66.	4C9	Lock Collar
30.	ST58	Clutch Yoke	67.	K92	Snap Ring
31.	S115	Beater Clutch Pin	68.	K90	Bearing
32.	S116	Beater Clutch Sprocket	69.	17G141	Bolt 3/8" x 1-1/4" GR.5
33.	S117	Beater Clutch Bushing	70.	S346	Light Bracket
34.	S118	Beater Shield Top	71.	BFR319	I-Bolt
35.	S119	Beater Side Shield	72.	S328	Edging 3-1/2"
36.	S120	Main Side Shield	73.	S403	Handle Grip
37.	D58	Shield Angle	*	S368	Complete Shifter

NOTES: * (Means Not Shown)

FIGURE 6



**FIGURE 6
BEVEL GEARBOX**

ITEM	PART NO.	DESCRIPTION
1.	5B10	1/4" x 1" Woodruff Key
2.	ST46	Gearbox Side Shaft
3.	3G9	Seal
4.	3G19	Snap Ring
5.	3G18	Race #15245
6.	3G7	Bearing #15101
7.	3G5	Gear
8.	3G1	Gearbox Housing
9.	3G2	Gearbox Gasket
10.	3G20	Fill Plug
11.	3G3	Cover
12.	3G9	Seal
13.	3G11	Nut
14.	5B10	1/4" x 1" Woodruff Key
15.	S134	Gearbox Front Shaft
16.	S135	1/4" x 1-1/4" Square Key
17.	3G4	Nut
18.	L3G24	Gearbox Bearing #15113
19.	S136	Seal
NOT SHOWN	ST47	Gearbox Complete

FIGURE 7

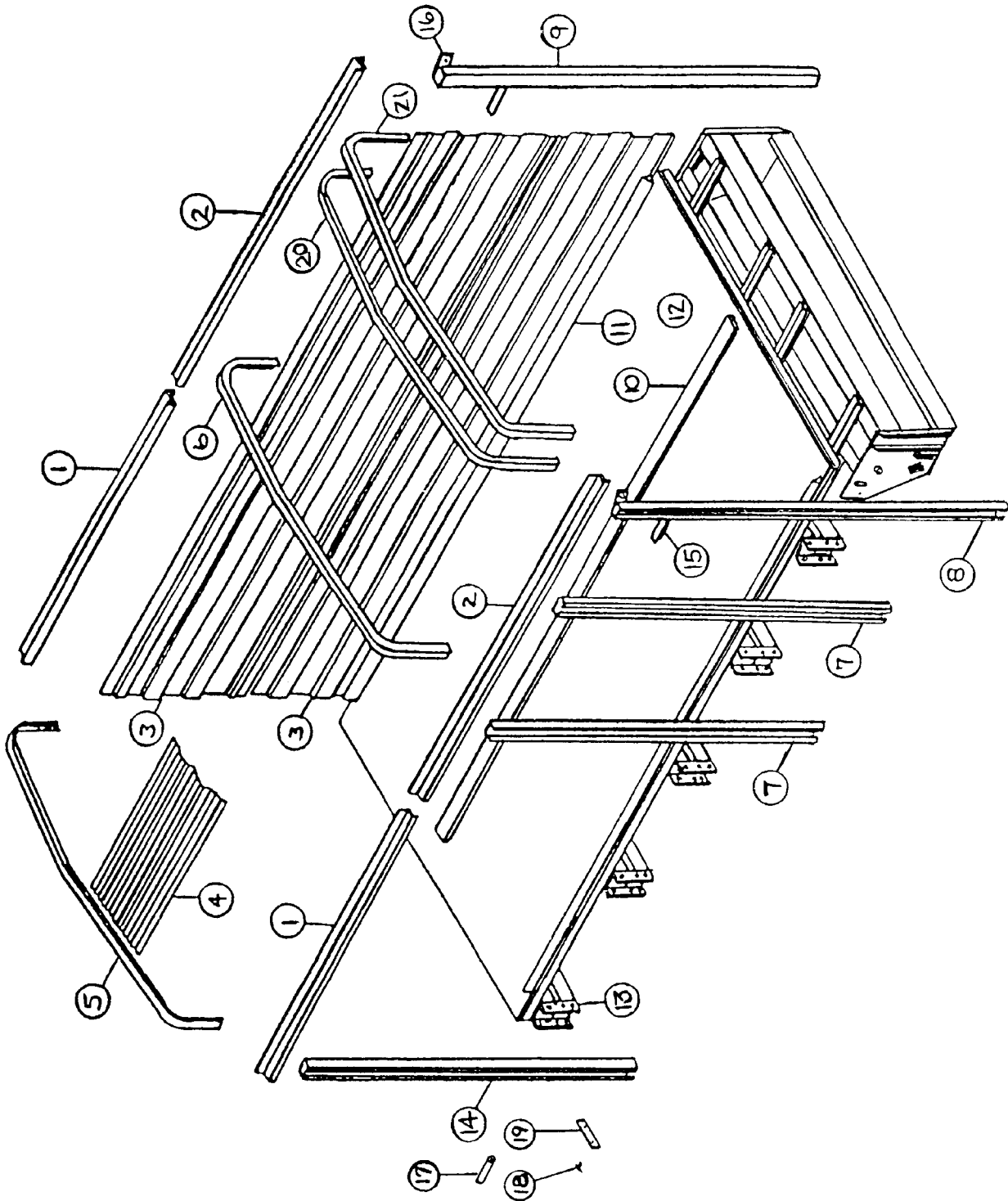

**FIGURE 7
7+4 BOX COMPONENTS**

ITEM	PART NO.	DESCRIPTION	ITEM	PART NO.	DESCRIPTION
1.	S146	Roof Sill Front Section 16'	9.	PB68	RH Rear Stake
*	S470	Roof Sill Front Section 17'	10.	S514	16' Apron Chain Center Spacer (F&R)
*	S147	Roof Sill Front Section 18'	*	S164	17' Apron Chain Center Spacer (F&R)
*	S471	Roof Sill Front Section 19'	*	S515	18' Apron Chain Center Spacer (F&R)
*	S297	Roof Sill Front Section 20'	*	S427	19' Apron Chain Center Spacer (F&R)
*	S472	Roof Sill Front Section 21'	*	S301	20' Apron Chain Center Spacer (F&R)
*	S502	Roof Sill Front Section 22'	*	S506	21' Apron Chain Center Spacer (F&R)
2.	S143	Roof Sill Back Section 16'	*	S511	22' Apron Chain Center Spacer (F&R)
*	S473	Roof Sill Back Section 17'	11.	S516	16' Apron Chain Side Spacer (F&R)
*	S144	Roof Sill Back Section 18'	*	S167	17' Apron Chain Side Spacer (F&R)
*	S474	Roof Sill Back Section 19'	*	S517	18' Apron Chain Side Spacer (F&R)
*	S298	Roof Sill Back Section 20'	*	S428	19' Apron Chain Side Spacer (F&R)
*	S475	Roof Sill Back Section 21'	*	S302	20' Apron Chain Side Spacer (F&R)
*	S503	Roof Sill Back Section 22'	*	S507	21' Apron Chain Side Spacer (F&R)
3.	S149	16' Side Steel	*	S512	22' Apron Chain Side Spacer (F&R)
*	S476	17' Side Steel	12.	S518	16' Floor Assembly (F&R)
*	S150	18' Side Steel	*	S170	17' Floor Assembly (F&R)
*	S477	19' Side Steel	*	S519	18' Floor Assembly (F&R)
*	S299	20' Side Steel	*	S429	19' Floor Assembly (F&R)
*	S478	21' Side Steel	*	S303	20' Floor Assembly (F&R)
*	S504	22' Side Steel	*	S508	21' Floor Assembly (F&R)
4.	S152	16' Roof Steel	*	S513	22' Floor Assembly (F&R)
*	S479	17' Roof Steel	13.	S268	Stake Pockets
*	S153	18' Roof Steel	14.	ST48	Front Stake
*	S480	19' Roof Steel	15.	PB106	Brace
*	S300	20' Roof Steel	16.	PB12	Door Hinge Bracket
*	S481	21' Roof Steel	17.	ST55	Stake Spacer
*	S505	22' Roof Steel	18.	ST57	Plastic Grommet for Cable
5.	ST61	Front Branch Guard (16'-18'-20')	19.	ST56	Cable Bracket
5A.	S482	Front Branch Guard (17'-19'-21')	20.	S236	Rear Roof Support (16'-18'-20') (F&R)
6.	ST60	Roof Support (16'-18'-20')	20A.	S500	Rear Roof Support (17'-19'-21') (F&R)
6A.	S483	Roof Support (17'-19'-21')	21.	S520	Rear Branch Guard (16'-18'-20') (F&R)
7.	ST49	Side Stake	21A.	S501	Rear Branch Guard (17'-19'-21') (F&R)
8.	PB140	LH Rear Stake	NOTE: * (Means Not Shown)		

FIGURE 8

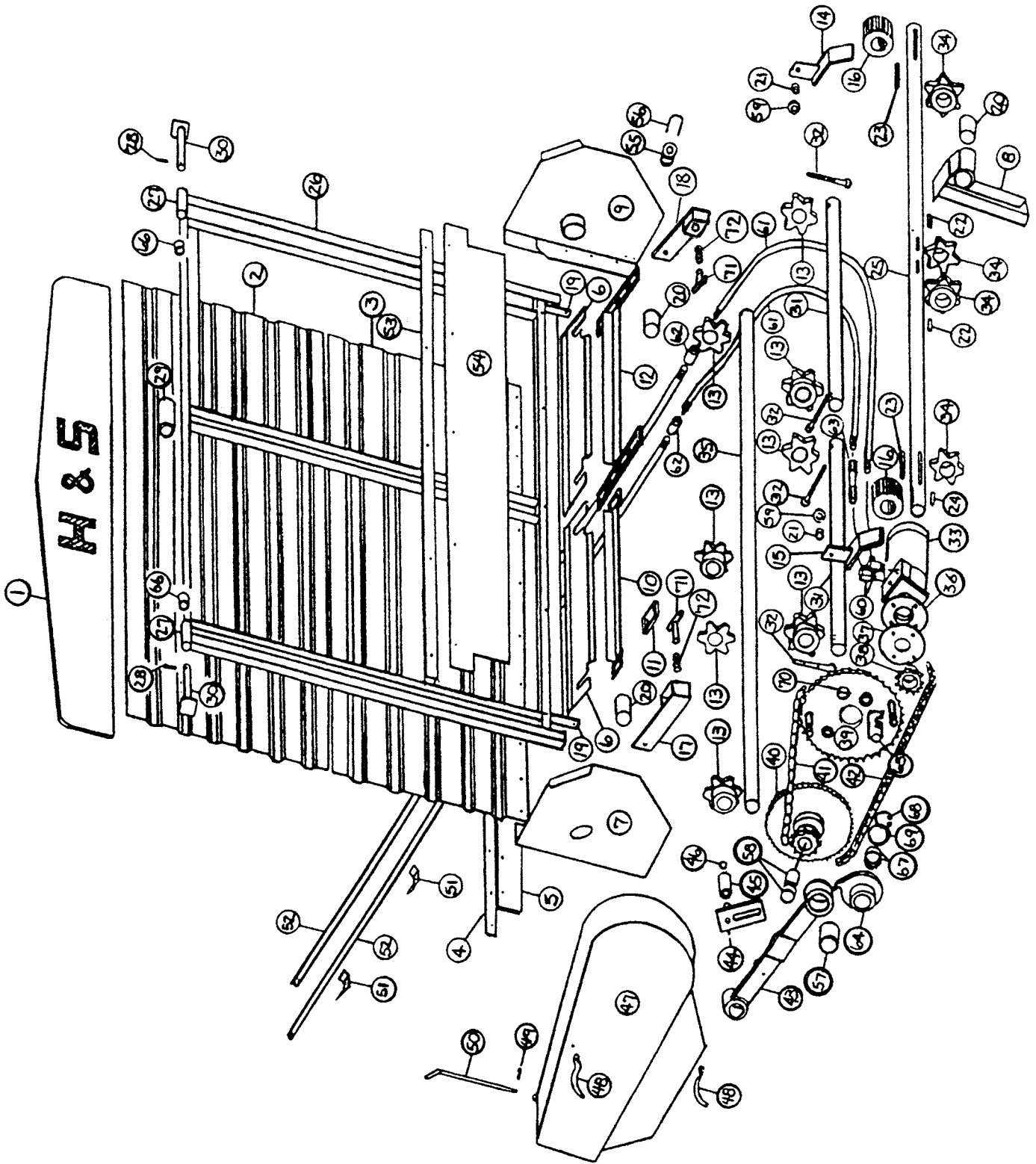

**FIGURE 8
REAR UNLOAD ASSEMBLY**

ITEM	PART NO.	DESCRIPTION	ITEM	PART NO.	DESCRIPTION
1.	PB72	Back Door Top Panel	37.	PB260	Hydraulic Motor Mount Washer
2.	PB23	Back Door Top Steel	38.	PB235	Sprocket 2000 Series
3.	PB24	Back Door Bottom Steel	39.	PB193	52T Sprocket
4.	S288	Seal Strap	40.	PB95	11T-84T Sprocket
5.	PB54	Rubber Seal	41.	PB114	#80 Chain 73 Pitches
6.	IFB56	Drive Shaft Panel	42.	PB97	#50 Chain 90 Pitches
7.	PB80	LH Drive Shaft Mount	43.	PB119	Drive Shaft Brace
8.	PB139	Center Bearing Bracket	44.	17G69	Chain Tightener Bracket
9.	PB82	RH Drive Shaft Mount	45.	23N238	Roller Chain Tightener
10.	S233	667H Pintle Slat with Attachment Links	46.	10R32	Snap Ring
11.	11S51	667H Pintle Connector Links	47.	PB138	Rear Shaft Shield
11A.	11S50	667H Pintle Attachment Links RH or LH	48.	S192	Handle Nuts
12.	S324	667H Complete Pintle Apron 16'	49.	T37	Cotter Pin
*	S325	667H Complete Pintle Apron 18'	50.	PB100	Hinge Pin
*	S326	667H Complete Pintle Apron 20'	51.	23N67	Hose Holder
13.	S60	Idler Shaft Sprockets	52.	PB101	Hydraulic Pipe 16'
14.	PB57	Latch Bracket RH	*	PB18	Hydraulic Pipe 18'
15.	PB58	Latch Bracket LH	*	PB102	Hydraulic Pipe 20'
16.	PB83	Latch Sprocket	53.	PB103	Poly Shield Strap
17.	75394	Rear Door Lock Latch LH	54.	PB104	Poly Shield
18.	75221	Rear Door Lock Latch RH	55.	F33	Cable Guide
19.	PB60	Latch Plate	56.	F32	U-Bolt
20.	23N17	Bushing 1-3/4" OD x 1-1/2" ID x 2-1/2"	57.	PB134	Bushing 2-1/2" OD x 2-1/4" ID x 1" Long
21.	PB61	Latch Pivot	58.	PB108	Bushing 1-1/2" OD x 1-1/4" ID x 1-3/4"
22.	PB87	Key 3/8" x 2" Square	59.	A34	Latch Washer
23.	PB133	Key 3/8" x 4-3/8" Square	60.	HE58	Elbow
24.	PB136	Key 3/8" x 2" Sq. w/Hardened Ends	61.	PB41	Hydraulic Hose 1/2" x 60"
25.	PB194	Drive Shaft	62.	PB105	1/2" Pipe Coupling
26.	PB73	Back Door Framework	63.	DF18	Check Valve
27.	PB65	Hinge Pin	64.	PB118	Rear Clutch Dog
28.	3G22	Expansion Pin	65.	PB191	Clutch Pin
29.	PB66	Guard	66.	PB130	Collar
30.	PB129	Hinge Pin	67.	PB135	Bushing
31.	PB89	Tightener Shafts	68.	23N227	Snap Ring
32.	A7	Idler Bolt 9"	69.	PB126	Clutch Sprocket Washer
33.	DF1	Hydraulic Motor	70.	PB190	Lynch Pin
34.	23N122	Drive Shaft Sprockets	71.	IFB109	Door Latch Pin
35.	PB90	Inside Idler Shaft	72.	IFB110	Door Latch Spring
36.	PB261	Hydraulic Motor Mount Spacer	NOTE: * (Means Not Shown)		

FIGURE 9

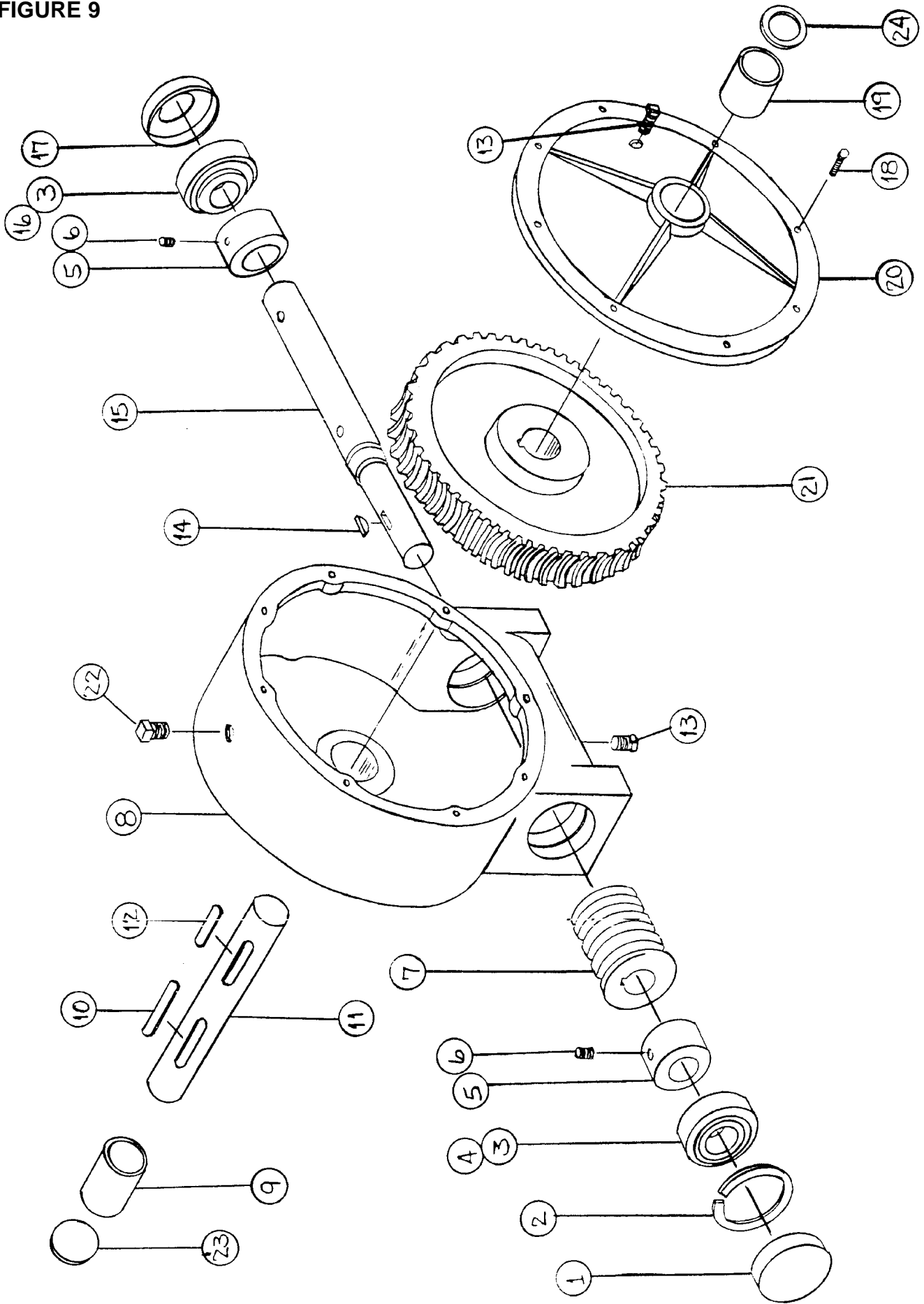

**FIGURE 9
WORM GEARBOX**

ITEM	PART NO.	DESCRIPTION
1.	G90	Dust Cap
2.	3G19	Snap Ring
3.	3G18	Race #15245
4.	3G7	Bearing #15101
5.	X9	Spacer
6.	G83	Set Screw
7.	G76	Worm
8.	G114	Gearbox Housing
9.	X8	Gearbox Bushing
10.	S138	3/8" x 2-3/8" Square Key w/Round Ends
11.	S139	Worm Gear Side Shaft
12.	S437	3/8" x 1-3/8" Square Key w/Round Ends
13.	G65	Plug 3/8"
14.	5B10	1/4" x 1" Woodruff Key
15.	S140	Worm Gear Front Shaft
16.	L3G24	Gearbox Bearing #15113
17.	G115	Seal
18.	G84	Cap Screw
19.	X75	Cover Bushing
20.	G116	Worm Gearbox Cover
21.	G77	Worm Gear
22.	G91	Vent Plug
23.	G117	Cap
24.	G120	Seal 1-7/8"
*	G118	Worm Gearbox Complete

NOTE: * (Means Not Shown)

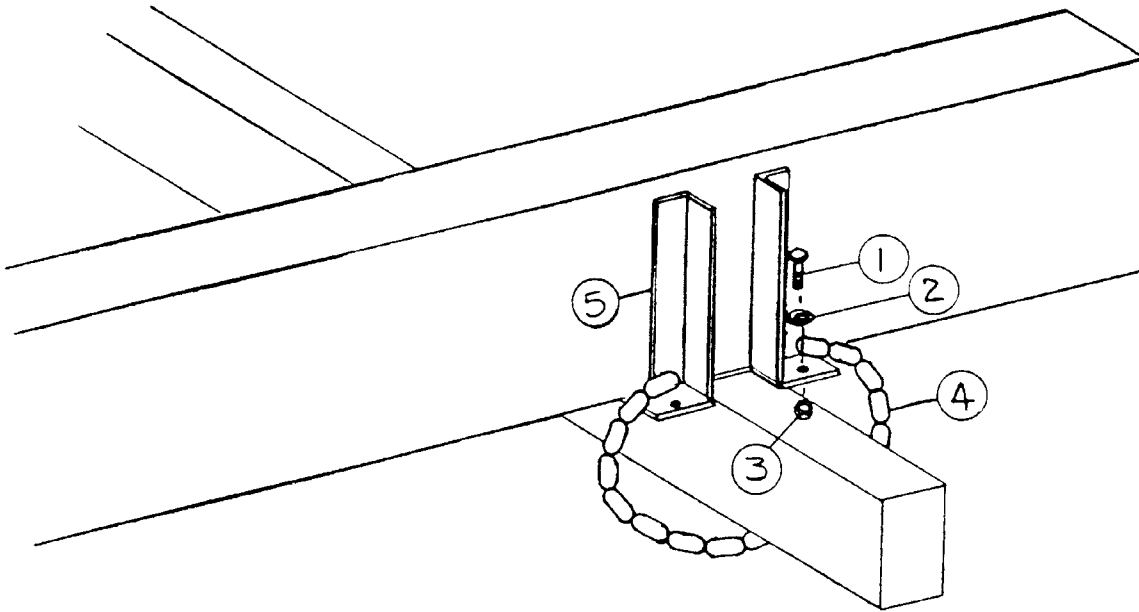
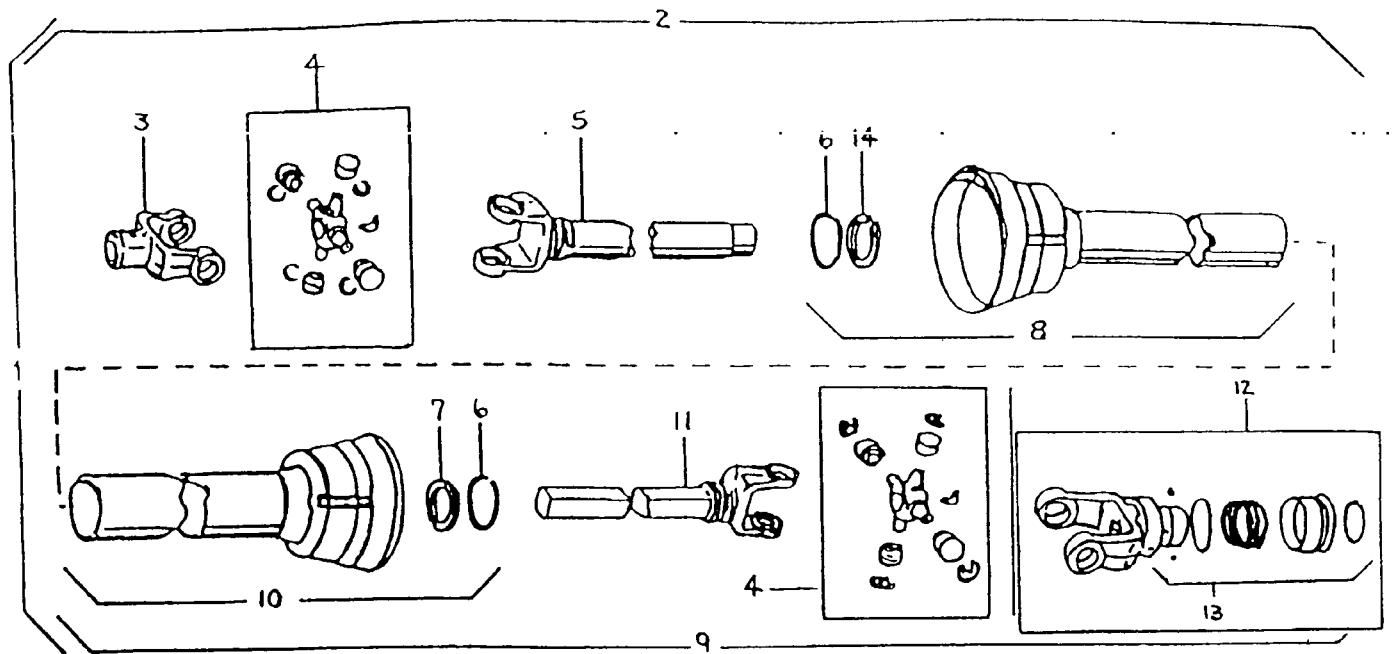

FIGURE 10
TIE DOWN KIT

ITEM	PART NO.	DESCRIPTION
1.	12V45	1/2" x 1-1/2" GR.5 Bolt
2.	K68	1/2" Flat Washer
3.	R11	1/2" Top Lock Nut GR.5
4.	S322	1/4" Chain 30-1/4" Long
5.	S323	Tie Down Bracket
6.	T9B	Tie Down Kit - Complete



**FIGURE 11
PTO PARTS
HD NEEDLE BEARING PTO**

ITEM	PART NO.	DESCRIPTION
1.	S372	PTO Assembly Complete
2.	S373	Machine Half PTO W/Shield
3.	S374	End Yoke - Machine Half
4.	S375	"W" Repair Kit
5.	S376	Yoke and Tube
6.	24N26	Bearing Retainer
7.	S206	Nylon Bearing
8.	S397	Inner Guard Includes Cent. & Item #6 & #14
9.	S377	Tractor Half PTO
10.	S398	Outer Guard Includes Item #6 & #7
11.	S378	Yoke and Shaft
12.	S379	Lock Yoke - Yoke Assembly
13.	S225	Spring Lock Repair Kit
14.	S396	Nylon Bearing
*	S402	Safety Manual

NOTE: * (Means Not Shown)

FIGURE 12

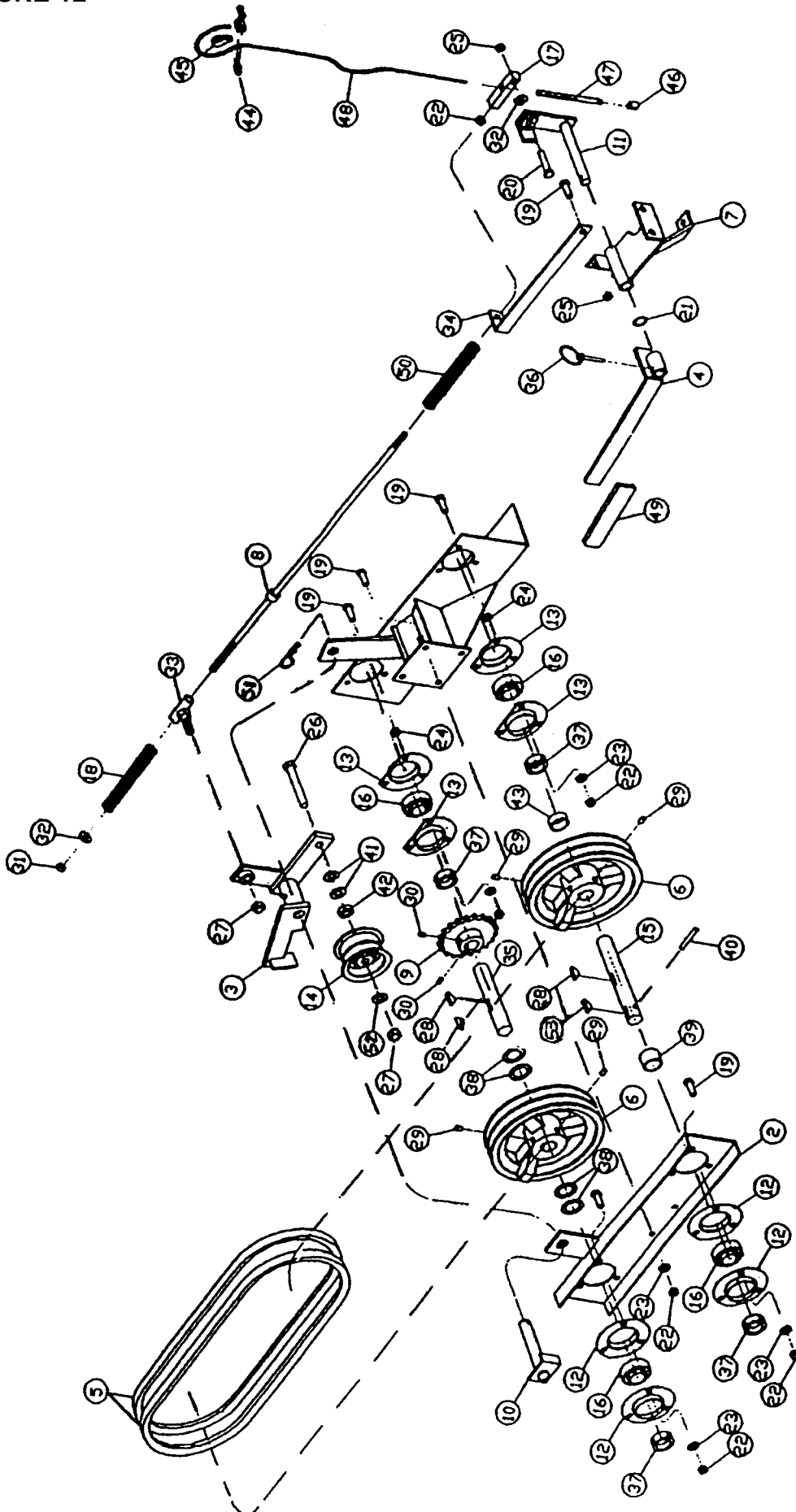

FIGURE 12
CROSS CONVEYOR CLUTCH - BELT DRIVE

ITEM	PART NO.	DESCRIPTION
2.	S335	Front Clutch Plate
3.	S341	Idler - Stop Assembly
4.	S337	Handle Lever
5.	S332	Drive Belt Set
6.	S342	Pulley
7.	S339	Handle Mount
8.	S343	Shifting Rod
9.	11S19	Sprocket 50B20
10.	S340	Tightener Pivot Shaft
11.	S338	Handle Lever
12.	4C7	Bearing Flange
13.	X85	Bearing Flange Sheared
14.	K156	Idler Pulley
15.	S458	Input Pulley Shaft
16.	4C8	Bearing
17.	S347	Shifter Rod End
18.	23N211	Spring 5/8"
19.	X111	3/8" x 1" Bolt GR.5
20.	BFR320	3/8" x 1-3/4" Bolt GR.2
21.	S352	Internal Star Washer
22.	K60	3/8" Nut
23.	B68	3/8" Lockwasher
24.	S355	3/8" Jam Nut
25.	K25	3/8" Locknut
26.	16SV91	1/2" x 3-1/4" Bolt GR.5
27.	R11	1/2" Top Locknut
28.	5B10	1/4" x 1" Woodruff Key
29.	---	3/8" Setscrew
30.	---	5/16" Setscrew
31.	A14	3/8" Nylock Nut
32.	X67	3/8" Flatwasher
33.	S344	Clutch Rod Slide
34.	S348	Spring Bracket
35.	S349	Drive Pulley Shaft
36.	S438	Clip Pin
37.	4C9	Bearing Lock Collar
38.	S345	Spacer (.074)
39.	K99	Spacer, 7/8"
40.	BFR335	5/16" x 2" Expansion Pin
41.	K68	1/2" Lockwasher
42.	23N94	Spacer, 9/16"
43.	K106	Spacer, 1/2"
44.	BFR220	Cable Clamp
45.	ES4	Thimble
46.	ES5	Cable Compression Sleeve
47.	S361	Stop Cable Stiffener
48.	S358	Emergency Stop Cable
49.	S362	Handle Lever Grip
50.	S369	Spring, 3/4"
51.	ES7	Hair Pin
52.	R35	1/2" Lock Washer (As Needed)
53.	S135	1/4" x 1-1/4" Square Key

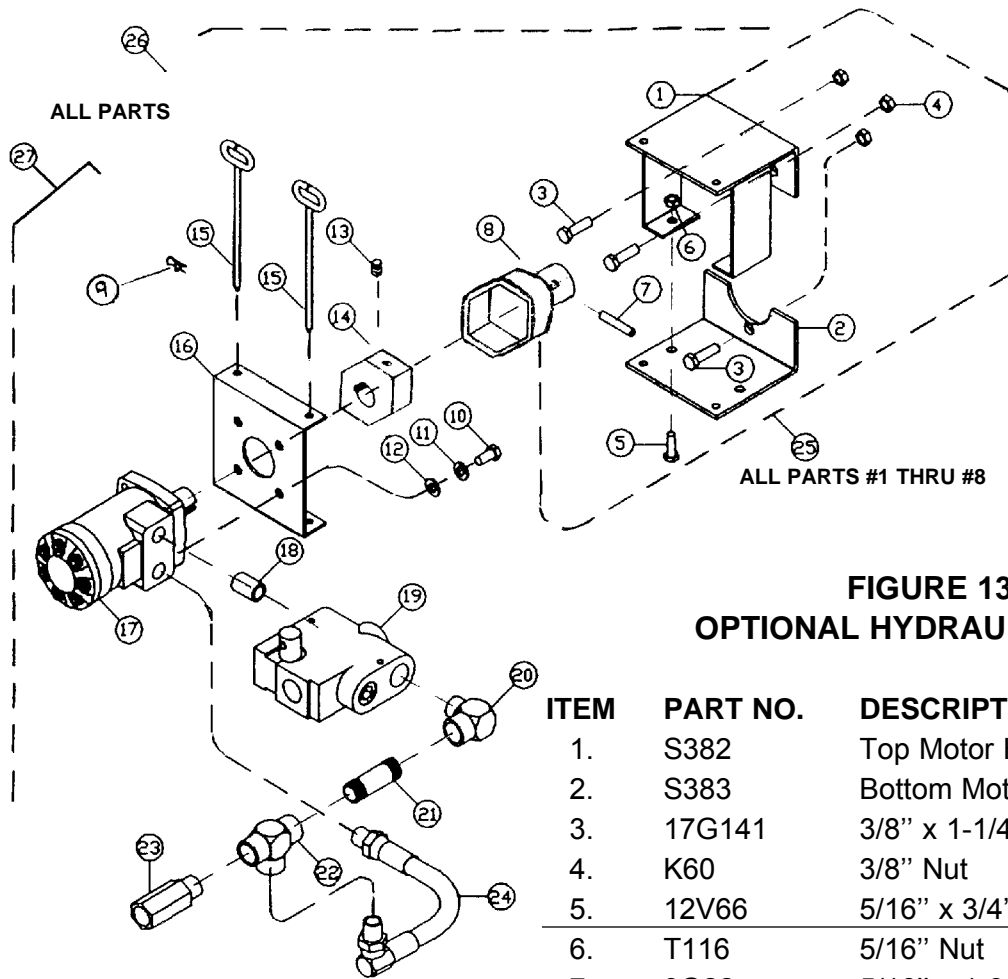

FIGURE 13
OPTIONAL HYDRAULIC DRIVE

ITEM	PART NO.	DESCRIPTION
1.	S382	Top Motor Hanger
2.	S383	Bottom Motor Hanger
3.	17G141	3/8" x 1-1/4" Bolt GR.5
4.	K60	3/8" Nut
5.	12V66	5/16" x 3/4" Bolt
6.	T116	5/16" Nut
7.	3G22	5/16" x 1-3/4" Roll Pin
8.	S411	Secondary Drive
9.	X97	Hair Pin
10.	G110	3/8" x 3/4" Bolt
11.	B68	3/8" Lockwasher
12.	X67	3/8" Flat Washer
13.	---	5/16" Set Screw
14.	S410	Primary Drive
15.	S386	Motor Unit Mount Pin
16.	S384	Hydraulic Motor Mount
17.	DF1A	Hydraulic Motor (Super 7+4)
*	ST88	Hydraulic Motor (Twin Auger)
18.	DF7	1/2" Close Nipple
19.	DF15	Flow Control Valve
20.	HE58	1/2" Street Elbow
21.	DF17	1/2" x 2" Pipe Nipple
22.	DF8	1/2" Pipe Tee
23.	DF18	1/2" Check Valve
24.	S395	Hydraulic Hose - 10-1/2"
25.	S388	Extra Unit Drive Kit
26.	S412	Drive Kit (complete Super 7+4)
27.	ST90	Drive Kit (complete - Twin Auger)

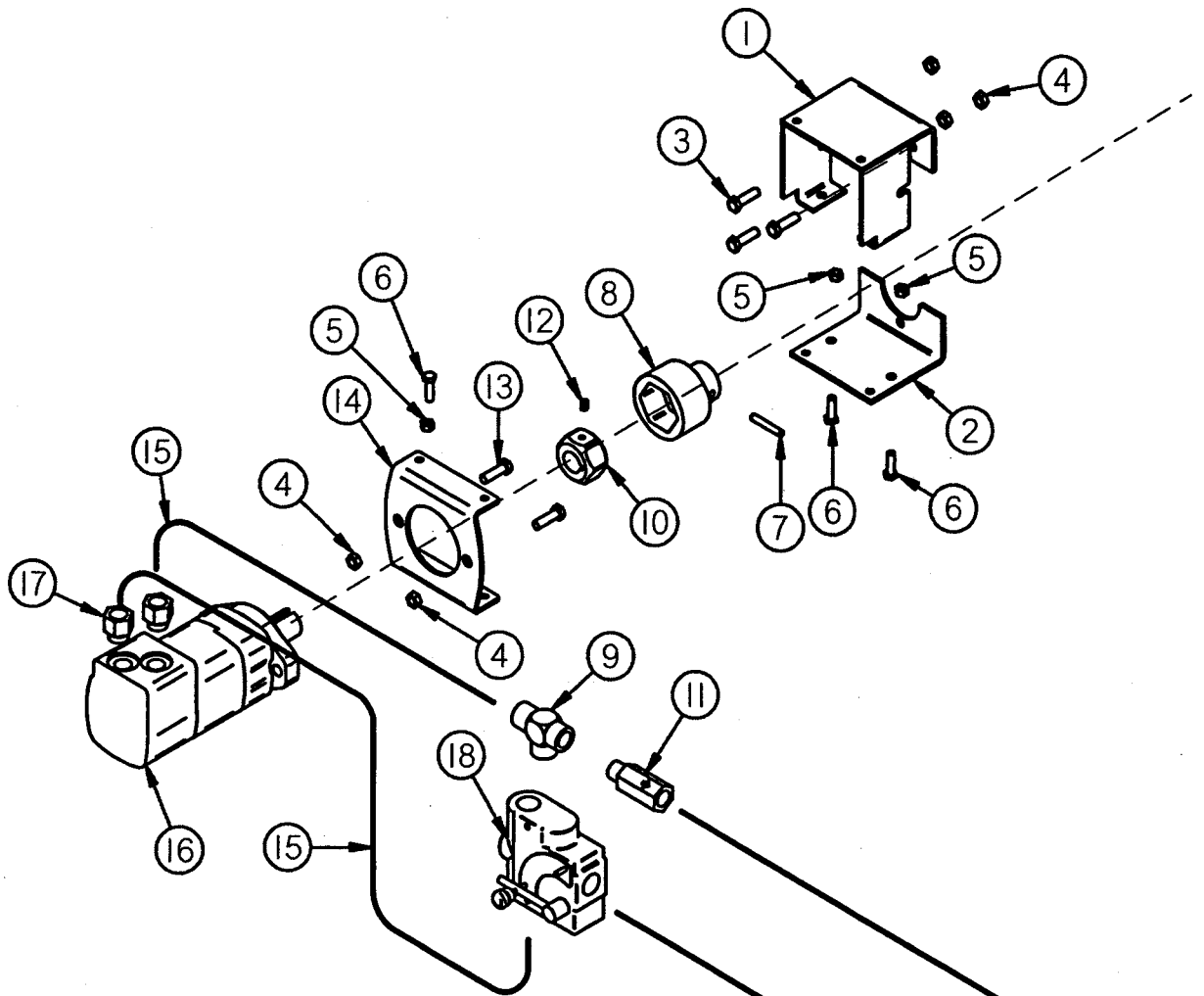

FIGURE 14
OPTIONAL FRONT HYDRAULIC DRIVE
(2000 SERIES)

ITEM	PART NO.	DESCRIPTION
1.	S382	Top Motor Hanger
2.	S383	Bottom Motor Hanger
3.	17G141	3/8" x 1-1/4" GR. 5 Bolt
4.	K60	3/8" Nut
5.	T116	5/16" Nut
6.	12V66	5/16" x 3/4" Bolt
7.	3G22	5/16" x 1-3/4" Expansion Pin
8.	S411	Secondary Drive
9.	S460	Male-Female Tee (5604-12)
10.	S463	Primary Drive
11.	PB185	Check Valve
12.	S435	5/16" Set Screw
13.	LW134	3/8" x 1-1/2" GR. 5 Bolt
14.	S464	Hydraulic Motor Mount
15.	S462	Hydraulic Hose 3/4" x 44"
16.	16SV150	Hydraulic Motor (104-1027-006)
17.	S461	O'Ring Adapter
18.	33SV74	Flow Control Valve

H&S MFG. CO.

products approved

for the

FEMA

SEAL OF QUALITY

